

***PERFORMER CUBXL***  
***mobile carpet cleaner***  
***and***  
**BRIDGEPOINT**  
**SYSTEM IV**

OPERATION &  
SERVICE  
MANUAL

**PROCHEM**

PROFESSIONAL CHEMICALS CORP  
325 S PRICE RD, CHANDLER, AZ

## INDEX

Acceptance of shipment	1	Loss of chemical	31-32
Battery maintenance	26	Loss of vacuum	31
Bolting down the unit	5	Loss of water pump pressure	29-30
Chemical flowmeter malfunctions	34	Loss of water pump volume	30
Chemical pumping system	13	Low water temperature	33
Chemical requirements	2	Maintenance	23-25
Cleaning	20-21	Oil requirements	2
Cleaning solution heat	21	Operation	18-23
Component repair	28	Positioning the unit in vehicle	3-4
Connection of unit to vehicle fuel	5-9	Pressure regulator	24
Daily maintenance	21-22	Pressure regulator maintenance	27
Dealer responsibility	1	Priming the chemical pump	19-20
Drive belt maintenance	26	Priming the water pump	19
Engine maintenance	25	Receiving and installing	1-10
Engine stops running	33	Specifications	iii
Engine will not start	32	Starting the unit	21-22
Fire extinguisher	10	Stopping the unit	19-20
Flood restoration	21	Systems	9-14
Freezing protection	22-23	Troubleshooting	29-34
Fuel requirements	2	Vacuum flow heat exchanger	16
General service adjustments	24	Vacuum pump maintenance	26
Heat exchanger maintenance	27	Vacuum system	14
Heat transfer system	15	Vacuum tank filter maintenance	26
Hose connections	18	Warranty	ii
Installation	2-10	Water pump maintenance	26
Installing trailer gas tank and line	9	Water pumping system	11-12
Installing waste tank in vehicle	5	Water requirements	2
Installing waste tank drain valve	10	Water supply connection	16
Lifting the unit	3		

## INDEX TO ILLUSTRATIONS

1/2" check valve (exploded view)	
Chemical check valve (exploded view)	46
Chemical parts listing	44
Chemical pump (exploded view)	46
Chemical pumping system (figure 9)	13
Dimensional data (figure 1)	4
Dual jet wand parts listing	49
Engine parts listing	43
Filler Neck details	7-8
Front view parts listing	39
Heat transfer system (figure 11)	15
Hose accessories parts listing	50
Instrumentation (figure 13)	17
Mounting plate installation (figure 2)	4
Pressure regulator manifold parts	38
Pulsation damper (exploded view)	46
Single jet wand parts listing	48
Vacuum flow heat exchanger (figure 12)	16
Vacuum flow heat exchanger parts listing	42
Vacuum system (figure 10)	14
Vacuum system parts listing	40-41
Water pump listing (exploded view)	45
Water pumping parts listing	36-37
Water pumping system (figure 8)	12
Water tank parts listing	47
Wiring diagram	35
Y-strainer (exploded view)	

---

---

The material contained within the *PROCHEM CUBXL Operation and Service Manual* is based on the latest information available at the time of publication. PROCHEM reserves the right to make changes in this manual without notice.

PROCHEM makes no warranty of any kind with regard to this material, including, but not limited to, the implied warranties of merchantability and fitness for a particular purpose.

PROCHEM shall not be liable for errors contained herein or for incidental or consequential damages in connection with the furnishing, performance or use of this material.

No part of this manual may be reproduced, photocopied, or translated (in part or whole) without prior written consent of *Professional Chemicals Corporation*.

---

---



## TABLE OF CONTENTS

Warranty	II
Specifications	III
Receiving and Installing	1-10
Systems	11-17
Operation	18-23
General Service Adjustments	24
Maintenance	25-27
Component Repair	28
Troubleshooting	29-34
Wiring Diagram	35
Parts Listing	36-50

## LIMITED WARRANTY

---

---

PROCHEM warrants your machine to be free of defects in material and workmanship. This warranty shall extend to the designated parts for the specific time period listed from the date of delivery to the user. If PROCHEM receives notice of such defects during the warranty period, PROCHEM will either, at its option, repair or replace products which prove to be defective.

Gasoline Engine ( <i>thru manufacturer or local dealer</i> ) . . . . .	2 years
Vacuum Pump ( <i>thru manufacturer or local dealer</i> ) . . . . .	2 years
Engine Heat Exchanger . . . . .	1 year
Water Pump . . . . .	1 year
Waste Pump . . . . .	1 year
Wands (Except shut off valve and orifices) . . . . .	1 year
Waste & Water Tanks . . . . .	1 year
Pressure Regulator . . . . .	1 year
All other components . . . . .	6 months
Battery ( <i>thru Interstate dealer only</i> ) pro-rated . . . . .	12 months

Disposable filters, electrical components, belts, fittings, hoses, o-rings, and other maintenance items are not under warranty.

This warranty shall not apply to defects resulting from improper installation or operation; inadequate maintenance by the customer; unauthorized modification; misuse; a unit which is improperly repaired; or exposure to freezing temperature conditions.

To obtain warranty service, products must be returned to a service facility designated by PROCHEM. Customer shall prepay shipping charges for products returned to PROCHEM for warranty service and PROCHEM shall pay for return of the products to customer.

PROCHEM makes no other warranty, either expressed or implied, with respect to this product. PROCHEM disclaims the implied warranties of merchantability and fitness for a particular purpose. Any implied warranty of merchantability or fitness is limited to the specific duration of this limited warranty.

This warranty gives you specific legal rights, and you may also have other rights which may vary from state to state, or province to province.

The remedies provided herein are the customer's sole and exclusive remedies. In no event shall PROCHEM be liable for any direct, indirect, special, incidental, or consequential damages, whether based on contract, tort, or any other legal theory.

Your PROCHEM unit is designed to give you years of reliable service. However, if a problem should arise after the warranty period, follow the troubleshooting procedures in the Operation and Service Manual. If you are still unable to determine the cause and solution to the problem, contact your nearest PROCHEM Service Center for details of the services available.

---

---

## SPECIFICATIONS

---

VAC RELIEF VALVE	14"Hg
WATER PUMP RPM	1550 RPM
WATER FLOW RATE	4.25 GPM
ENGINE SPEED (with 100 ft vac hose and water pump on)	3000 RPM
WATER PUMP PRESSURE	1000 PSI
WASTE TANK CAPACITY	52 Gallons
WASTE TANK/ENGINE SHUT-OFF ACTIVATION POINT	appx. 44 gal
CONSOLE WEIGHT	appx. 442 lbs
CONSOLE W/WASTE TANK WEIGHT	appx. 480 lbs

---

# PERFORMER CUBXL OPERATION AND SERVICE MANUAL

## 1 RECEIVING AND INSTALLING

This chapter of the operators manual contains information on receiving, preparing and installing the *Performer CubXL*.

**GENERAL:** This operation and service manual is written specifically for the *PROCHEM PERFORMER CUBXL CARPET CLEANER*, manufactured by *PROFESSIONAL CHEMICALS CORPORATION*.

**DEALER RESPONSIBILITY:** The *PROCHEM* dealer from whom you purchased this mobile cleaning unit is responsible for supervising the correct installation of the machine and for initial training of your operators and maintenance personnel in the proper operation and maintenance of this unit. Make certain that you receive these instructions.

**ACCEPTANCE OF SHIPMENT:** Every part of your *PERFORMER CUBXL* Carpet Cleaning unit was carefully checked, tested, and inspected, before it left our manufacturing plant. Upon receiving the unit, make the following acceptance check:

1. The unit should not show any outward signs of damage. If any damage is found, notify the **CARRIER IMMEDIATELY**.
2. Check your equipment and packing list. The standard *PERFORMER CUBXL* unit should arrive equipped with the following items (unless otherwise specified) as well as any extra accessories which were ordered:
  - A) Performer CubXL console
  - B) Waste tank.
  - C) Carpet Wand.
  - D) 100 ft., of 1/4 I.D. pressure hose.
  - E) 100 ft., of 2" vacuum hose.
  - F) Vacuum hose connector.
  - G) 50 ft water hose
  - H) Convenience outlet hose.
  - J) Installation bolt kit
  - K) Waste tank drain valve.
  - L) Waste tank drain hose.
  - M) Installation mounting plates
  - N) Clamps for hoses.
  - O) Fuel line installation hoses and fittings.
  - P) Operation & Service Manuals
    - a. Performer Cub
    - b. Gas Engine
    - c. Water Pump
    - d. Vacuum Pump

**FUEL REQUIREMENTS:** We recommend the use of clean, fresh, unleaded gasoline intended for automotive use. **DO NOT MIX OIL WITH GASOLINE.** Leaded gasoline may be used if lead-free is not available. 77 Octane minimum is recommended. Using an unleaded gasoline will result in fewer combustion deposits and longer valve life.

**NOTE;** The use of gasoline which contains alcohol, such as gasohol, is NOT recommended. If, however, gasoline with alcohol is used, it **MUST NOT** contain more than 10 percent ethanol and **MUST** be removed from the engine during storage. **DO NOT** use gasoline containing Methanol.

For additional information see "*Storage Instructions*" in the *Briggs and Stratton Operation and Maintenance Manual* which has been provided.

**OIL REQUIREMENTS:** We recommend using Briggs and Stratton 10W/30 high quality detergent oil (B & S #272001) or 30 weight (B & S #100005). If these are not available, use a high quality detergent oil classified "for service SF, SE, SD or SC". No Special additives should be used with recommended oils. For additional information see page 2 of the *Briggs and Stratton Operation and Maintenance Manual* which has been provided.

**WATER REQUIREMENTS:** If you are operating this unit in an area where the unit will be using water in which the hardness exceeds five (5) grains (85 parts per million), a suitable water softener should be installed. The *PROCHEM PERFORMER CUBXL* at full pump output, requires 270 gallons per hour at 20 to 90 PSI. A water supply hose capable of delivering this volume at the above pressure is required.

**CHEMICAL REQUIREMENTS:** The *PROCHEM PERFORMER CUBXL*, due to its chemical injection pump design, can be used with a variety of chemical compounds, (either acid or alkaline), depending on the job to be done. However, to obtain optimal results with this unit, we recommend using the *PROCHEM* line of chemicals. For information on the Chemicals *PROCHEM* can provide for your cleaning operation, consult your *PROCHEM* manual or contact your nearest *PROCHEM* dealer.

**INSTALLATION:** Prior to starting the installation, **FIRST** read the **ENTIRE** "Installation Section" of this manual. The following recommendations should be considered **BEFORE** installing this unit.

- A. Your unit should not be mounted in any motor vehicle of less than 1/2 ton capacity. If your unit is mounted on the large water tank assembly, a 3/4 ton capacity vehicle is required.

- B. If mounting in a trailer, make certain that the trailer is rated for the total weight of the unit AND trailer. Electric or hydraulic brakes should be provided, and a strict compliance of any State or Federal vehicle laws **MUST** be maintained.
- C. The vehicle tires should have a load rating above the combined vehicle and unit weight.
- D. If a wooden floor between the vehicle's floor and the unit is desired, we recommend using 1/2" thick MARINE plywood.
- E. If using a trailer, the *PERFORMER CUBXL* console should be positioned in order that it balances properly with respect to the axle.

**WARNING:**

DO NOT INSTALL THE *PERFORMER CUBXL* IN ANY MOTOR VEHICLE WHICH REQUIRES HIGH OCTANE GASOLINE. The *CUBXL* engine is designed to use unleaded gasoline. HIGH OCTANE GASOLINE WILL DAMAGE THE ENGINE.

1. **LIFTING THE UNIT ON THE VEHICLE:**

We recommend using a fork lift to lift the unit onto the vehicle. Position the forks under the unit from the front, making **CERTAIN** that the forks are spread to the width of the base.

2. **POSITIONING THE UNIT IN VEHICLE:**

Because vehicles vary in size and openings, individuals have their own preferences as to where they want their units installed. We do not recommend any specific location for the *PERFORMER CUBXL CARPET CLEANER*. However, we do **STRONGLY** advise that enough space is provided to assure ample room for service and maintenance. In addition, the unit should be positioned in such a manner that mounting does not interfere with or endanger any vital components on the vehicle.

**NOTE:** For individuals who wish to make an engineering layout prior to positioning the unit, refer to page 4, figure 1, for console and waste tank dimensions.

DIMENSIONAL DATA (figure 1)

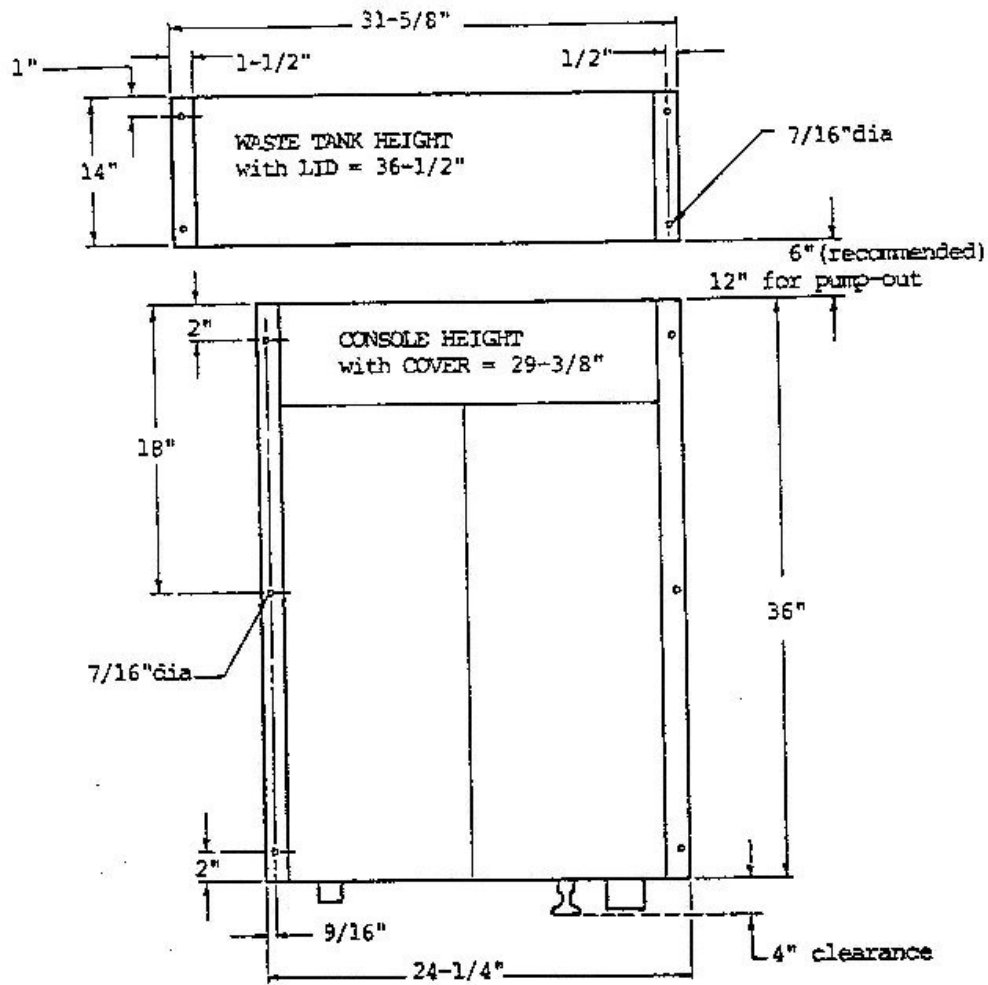

MOUNTING PLATE INSTALLATION (figure 2)

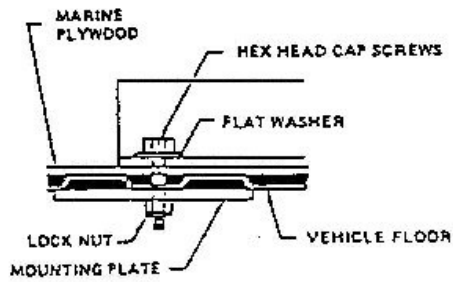

### 3. BOLTING DOWN THE UNIT AND WASTE TANK:

Once the unit and waste tank are positioned in the vehicle in the desired location, you may proceed. **NOTE:** When positioning the waste tank with respect to the console, hook up the vacuum hose and any other hoses which may connect the console and waste tank, This will ensure that the waste tank is positioned correctly.

**CAUTION:** Before drilling any mounting holes in the vehicle floor, make certain that when drilling, you will not do any damage to the gas tank, gas lines, or any vital component which might effect the operation or safety of the vehicle.

- A. Using the console and waste tank mounting holes as a template, drill four 7/16" diameter holes for mounting the console and four more 7/16" diameter holes for mounting the waste tank.
- B. Using the installation hardware kit:
  - a) Insert four 3/8" hex head cap screws through the mounting holes in the *PERFORMER CUBXL* console, and four more 3/8" hex head cap screws through the mounting holes in the waste tank.
  - b) Install the mounting plates underneath the vehicle floor. (Refer to page 4, figure 2,).
  - c) Screw the 3/8" hex head lock nuts on the mounting screws and tighten them until the console and the waste tank are firmly secured.

### 4. CONNECTION OF UNIT TO VEHICLE FUEL SUPPLY:

*Under NO circumstances should you splice into any of the vehicle fuel lines.*

READ THESE INSTRUCTIONS ENTIRELY BEFORE PROCEEDING.

**CAUTION:** Due to the positioning of the injection nozzle on certain vehicle fuel tanks, it may be necessary to drain the tank in order to prevent the spilling of an excessive amount of gasoline.

- A. Select a location on the vehicle floor to drill a hole for the bulk head adaptor. **NOTE:** This location should be situated in a position that eliminates the possibility of gas line contact by either the operator(s) or accessories during the working hours or maintenance periods. We supply steel braid fuel hose. Make certain that the hose will reach the location you choose.



**CAUTION: BEFORE DRILLING** the gas line hole in the vehicle floor, make certain when drilling you will not do any damage to the gas tank(s), gas lines, brake lines, or any other vital component which might effect the operation or safety of the vehicle.

- B. Drill a 5/8 (.625) diameter hole through the vehicle floor.
- C. Install the 1/8" bulkhead adaptor by inserting adaptor and tightening the nut on the opposite side of the van floor. (figure 3).
- D. Attach a 1/8P X 1/4T elbow to the bulkhead adaptor on one end (figure 3). Attach a 1/8" street elbow and a 1/8P x 5/16H barb fitting to the other end of the bulkhead adaptor.
- E. Connect one 45-1/2" stainless steel hose from the fuel pump on the console to the bulkhead adaptor.
- F. Disconnect from the filler neck the 2 hoses which connect the filler neck and the fuel tank by loosening the hose clamps.
- G. Remove the filler neck from the vehicle. If screws are used for mounting, remove them and save for re-installation. If the filler neck is mounted with rivets, it will be necessary to drill the rivets out and purchase the appropriate size sheet metal screws for re-installation.
- H. Select a suitable location for drilling the hole in the filler neck (figure 4).  
**NOTE:** The desired location for this hole may vary. It is important that you are able to re-install the filler neck without interference from the fittings which you are adding. Therefore, choose this location wisely before proceeding.
- I. Drill a 1/2" diameter hole in the filler neck after you are CERTAIN that you have chosen the proper location (figure 4). **NOTE:** When assembling pipe fittings, teflon thread sealant must be used.
- J. Attach a 1/8" street elbow to one end of the short bulkhead adaptor (figure 5). Slide one of the seals over the threads of the bulkhead adaptor against the hexagon area. Next, attach the 25", 36" or 45" stainless steel hose to the 1/8" street elbow. Choose a length that will reach through the filler neck to the bottom of the fuel tank. **NOTE:** If the chosen hose is too short or too long, the unit will run out of fuel before the vehicle fuel tank is empty.

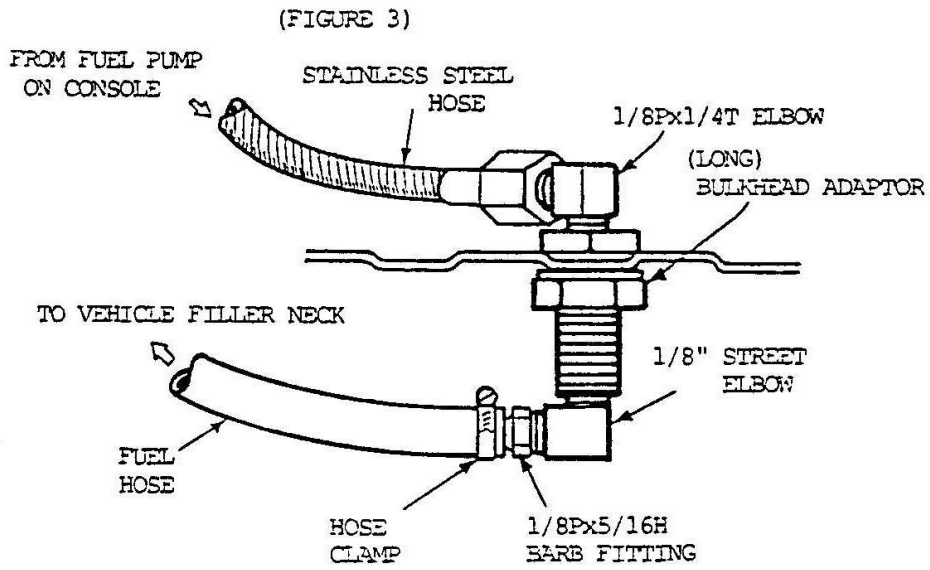

(FIGURE 4)

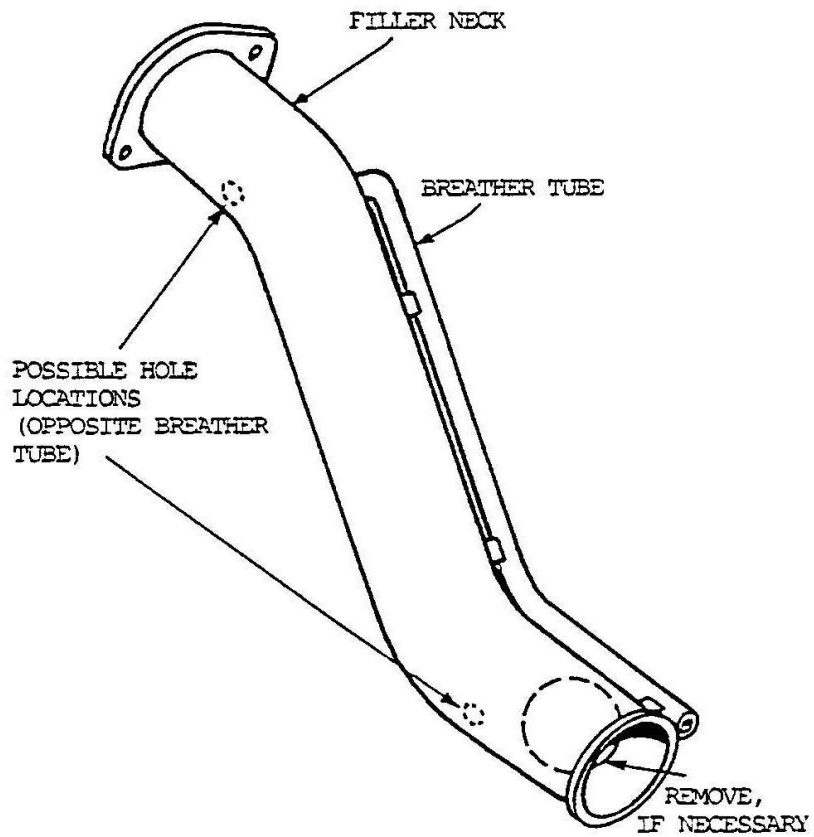

(FIGURE 5)

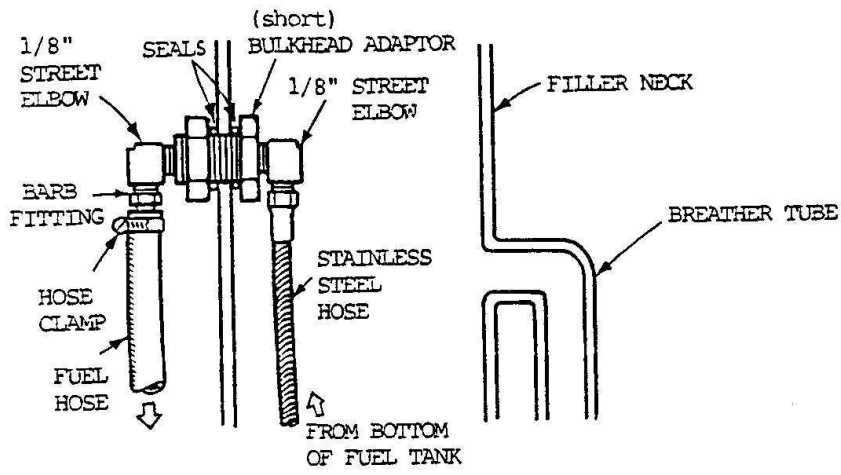

(FIGURE 7)

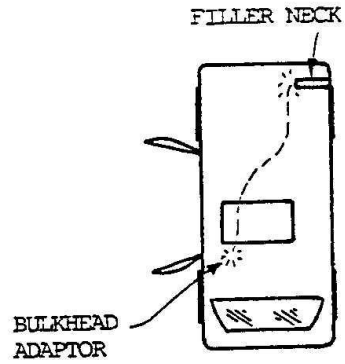

(FIGURE 6)

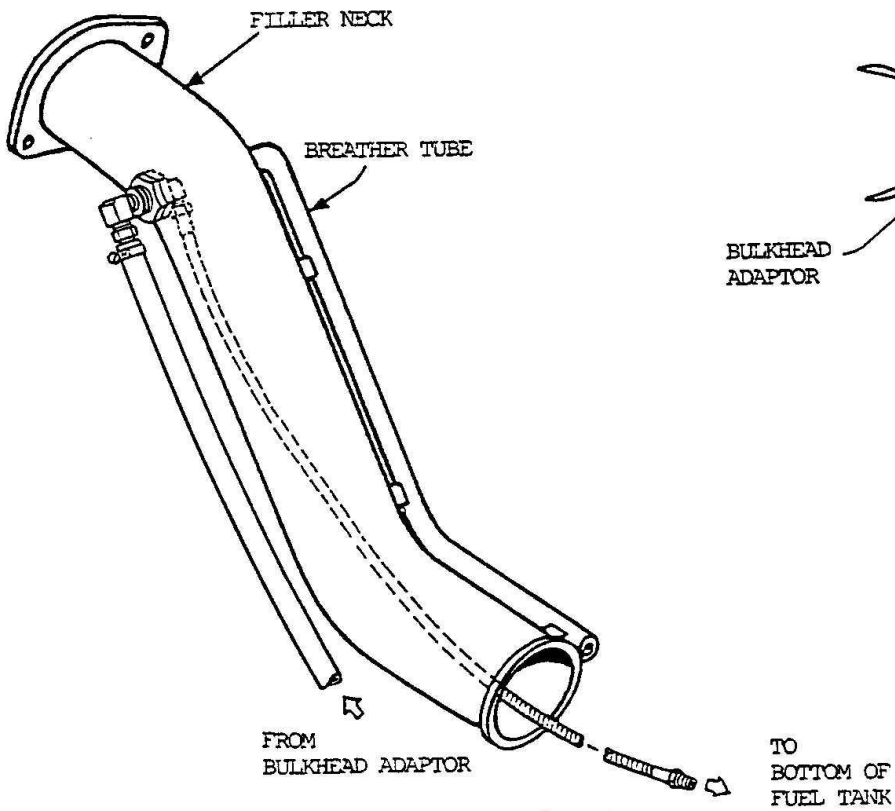

- K. Insert the stainless steel hose (bulkhead connector first) into the filler neck until the male threads on the bulkhead connector are protruding through the 1/2" hole. Slide the other seal over the threads and tighten the hexhead nut over the seal (figure 5). Attach the 1/8" street elbow and 1/8P x 5/16H barb fitting to the bulkhead connector, outside the filler neck. Make certain the fuel hose and fittings remain positioned parallel to the filler neck (figure 6).
- L. Using a hose clamp connect one end of the 5/16 fuel hose to the fittings on the outside of the filler neck (figure 5).
- M. Re-install the filler neck on the vehicle.
- N. Insert the filler neck fuel hose into the fuel tank and make certain the end is at the bottom of the tank.
- O. Re-connect the 2 hoses which connect the filler neck and the fuel tank. Make certain they are clamped correctly.
- P. Route the 5/16" fuel hose underneath the van from the filler neck to the bulkhead connector (figure 7). Use the cable ties to secure the hose. Cut off any excess hose and attach to the barb fitting with a hose clamp.  
**CAUTION:** When routing this hose underneath the vehicle, make CERTAIN that you do not place the hose in any location where damage may occur to the hose or vehicle. AVOID any contact with moving parts, areas of high temperature, or sharp objects.

5. **INSTALLING THE GAS TANK AND GAS LINE (TRAILER):**

For TRAILER installations we recommend the following.

- A. Strict compliance of any Federal or State law must be maintained.
- B. Provide a SAFE gas tank which is manufactured specifically for gasoline, has a proper filling cap, and an outlet connection that is the same size as the inlet connection on the unit.
- C. DO NOT MOUNT THE GAS TANK INSIDE THE TRAILER WITH THE UNIT.
- D. Mount the gas tank where it will be protected from any vehicle collision.
- E. When installing the gas line from the tank to the unit, use the proper size gas line.

6. **CONNECTING THE WASTE TANK TO THE UNIT:**

Maintain the proper distance between the console and the waste tank when positioning the components in the vehicle. Do not reverse the hoses when reattaching them to the waste tank.

7. **INSTALLING WASTE TANK DRAIN VALVE:**

The drain valve may be installed directly on the waste tank with a flexible hose. If you prefer, it may be installed on the end of a lower flexible hose, in which case a 2" I.D. flexible heavy duty hose is required.

8. **FIRE EXTINGUISHER:**

We recommend that a fire extinguisher, preferably rated for A, B, & C type fires, be installed inside the vehicle.

## 2 SYSTEMS

This chapter of the operators manual divides the unit up into systems and explains how each system works. Before proceeding into the operational and maintenance sections of this manual, we recommend acquiring a basic knowledge of how this unit functions, therefore, read the following section of this manual carefully and completely.

### 1. WATER PUMPING SYSTEM: (See figure 8, page 12)

Cold water enters the console through the water inlet connection at the front of the unit. The water then flows through a float valve into the water box. The float valve ensures that water flows into the system only when it is needed. The water box contains a temperature relief valve which protects the water pump from excessive temperature. If the temperature is over 165°F, the valve opens and allows the water box to empty into the waste tank. Next the water flows into the water pump. The water pump has a pulsation damper and a pressure regulator. The pulsation damper is a nitrogen-charged accumulator which reduces pressure fluctuations. The pressure regulator is a safety device which bypasses water back to the water box if it should exceed the desired settings. The pressurized water then goes into the exhaust heat exchanger which raises the temperature. On the check valve itself is a tee which allows water to constantly re-circulate through the heat exchanger and become continually hotter, unless the temperature solenoid valve is open. On the outlet side of the heat exchanger piping is a temperature sensor which is attached to a temperature solenoid valve. If the water temperature exceeds 240 degrees, the solenoid valve will open, allowing hot water to be released into the vacuum inlet tube and cold water to flow into the pumping system. This valve will close when the temperature drops down to 195 degrees. From the heat exchanger the hot pressurized water flows through a check valve to a tee where the chemical is injected. The check valve prevents separately pumped chemicals from reaching the water pump. The check valve constantly sends water to the water box which contains a bypass orifice. This creates constant water circulation and prevents excessive heat. The solution then flows through a Y-strainer, which filters debris, to the solution outlet at the front of the console.

# WATER PUMPING SYSTEM

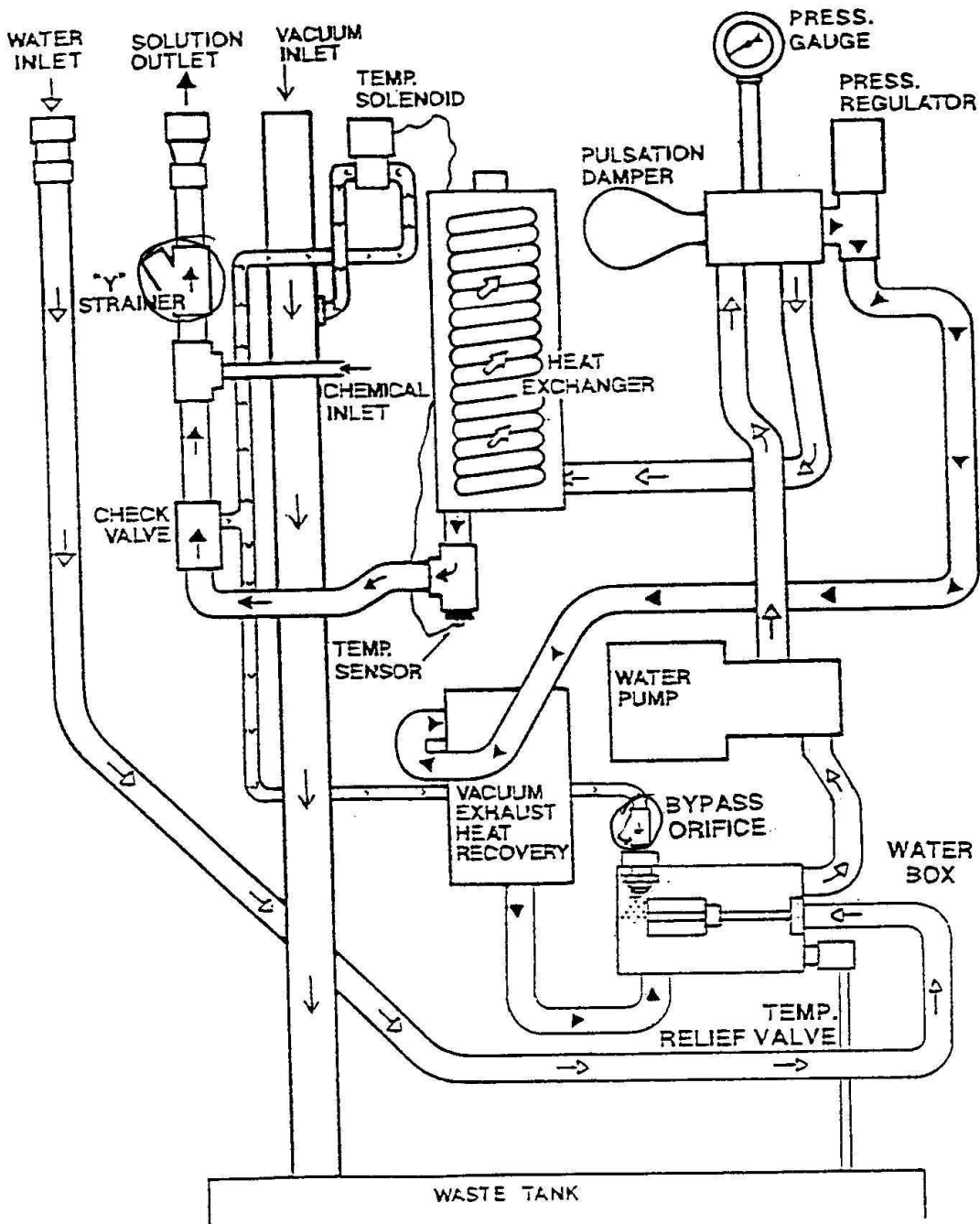

2. CHEMICAL PUMPING SYSTEM: (See figure 9)

The chemical is drawn through a strainer from the chemical container to the flowmeter. The flowmeter indicates the rate of chemical flow. The chemical then flows through an inlet check valve into the chemical pump. The chemical pump then injects the chemical through an outlet check valve to the 3-way valve on the instrument panel. This valve turns the chemical flow on or off and primes the chemical pump as well. Next, the chemical flows to the solution outlet piping.

CHEMICAL PUMPING SYSTEM (figure 9)

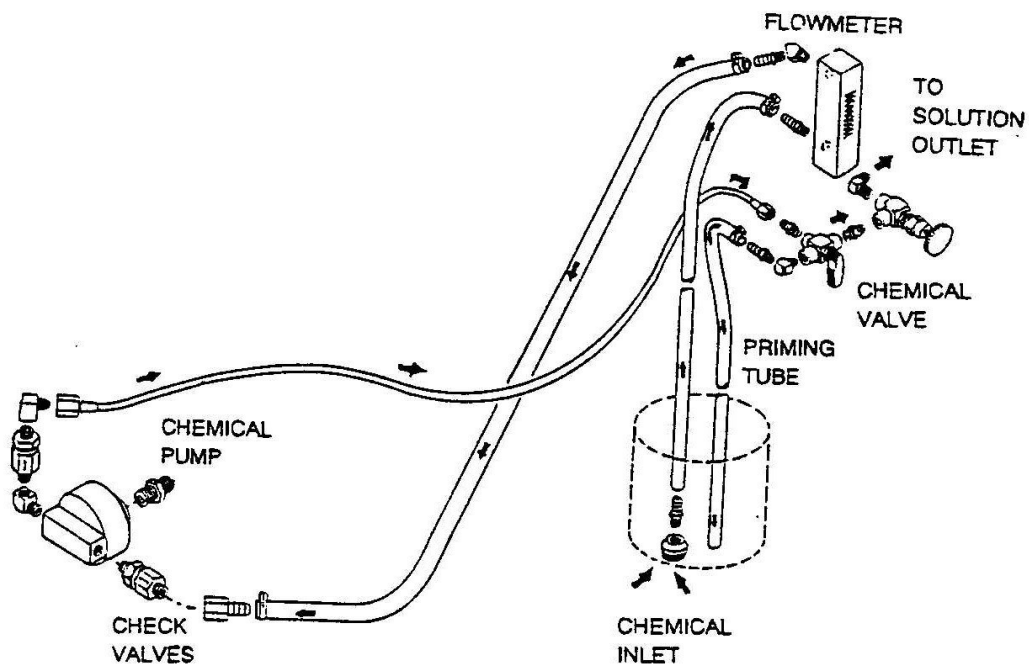



### 3. VACUUM SYSTEM: (See figure 10)

Vacuum flow begins at the cleaning tool, with a mixture of air and spent chemicals being drawn into the vacuum inlet at the front of the console. This mixture then flows into the waste tank where larger particles are removed by a strainer basket. The fluid and smaller waste particles are deposited in the waste tank. A level sensor switch has been provided to automatically shut the unit down before it overfills past its capacity. This prevents moisture from being drawn into the vacuum pump. Next, air flows through an additional filter, which removes smaller particles, to the vacuum pump. On the vacuum pump is a relief valve which releases air into the system if the vacuum exceeds 14"Hg. The air is then discharged from the vacuum pump through a silencer into the atmosphere.

VACUUM SYSTEM (figure 10)

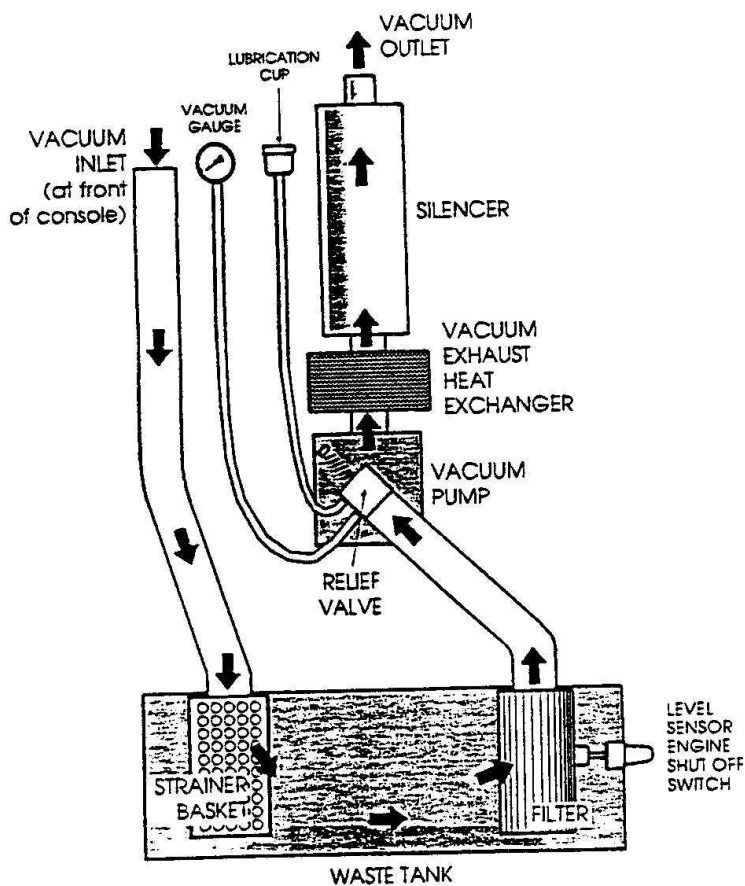

3. HEAT TRANSFER SYSTEM: (See figure 11)

Heat transfer begins with the hot exhaust from the engine which flows through a stainless steel tube into the heat exchanger. Pressurized water from the water pump flows through a coil inside the heat exchanger where heat is absorbed from the engine exhaust. On the outlet side of the heat exchanger is a temperature sensor which is attached to a temperature solenoid valve. If the water temperature exceeds 240 degrees the solenoid valve will open, allowing hot water to be released into the vacuum inlet tube and cold water to flow into the pumping system. This valve will close when the temperature drops back down to 212 degrees. The hot water then flows through a check valve to the solution outlet at the front of the console.

HEAT TRANSFER SYSTEM (figure 11)

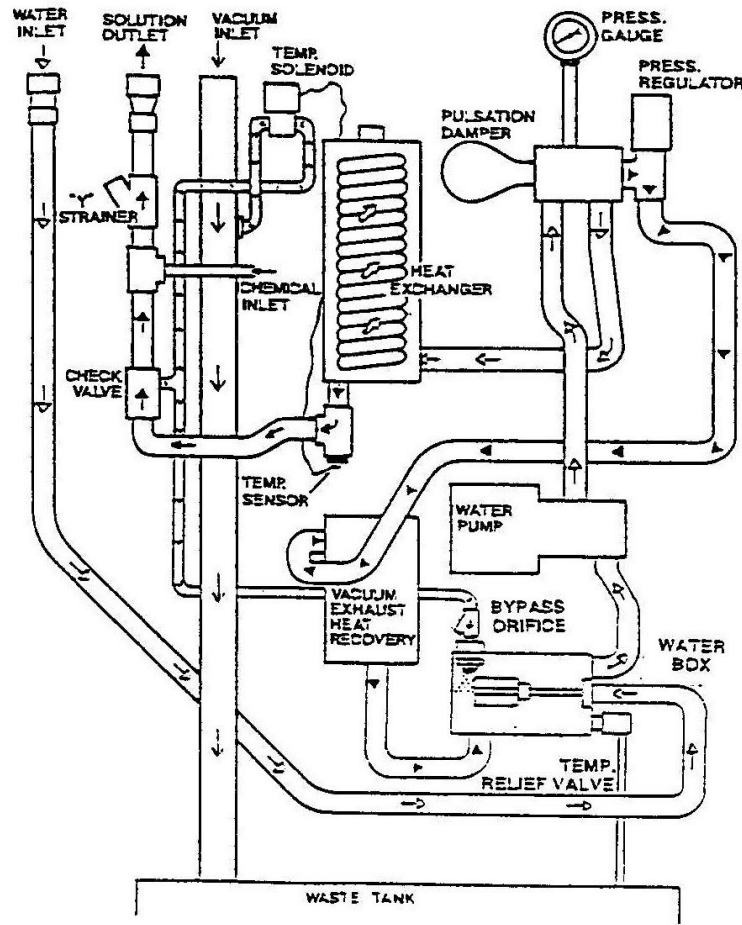

## VACUUM FLOW HEAT EXCHANGER: (See figure 12)

On units equipped with a vacuum flow heat exchanger, the vacuum exhaust exits through a box which contains a heat exchanger. The vacuum exhaust then exits and flows through a silencer into the atmosphere. Water from the pressure regulator bypasses into this heat exchanger where it is heated by the vacuum exhaust. The water then flows through water tank to the water pump.

VACUUM FLOW HEAT EXCHANGER (FIGURE 12)

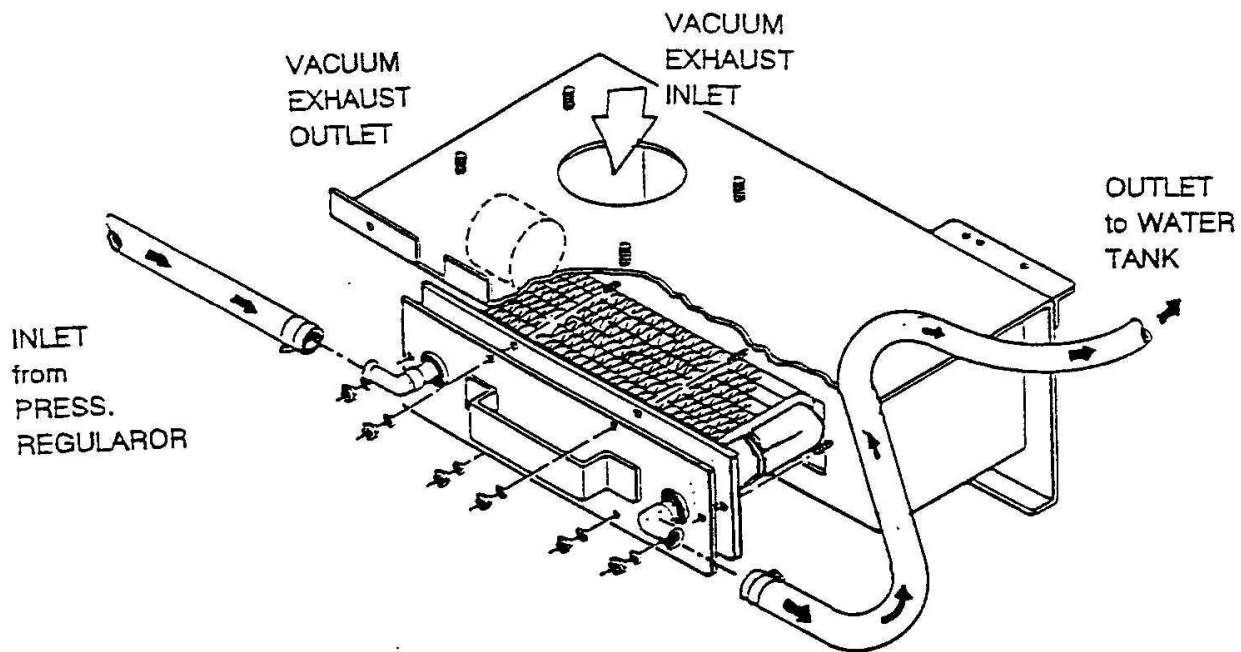

INSTRUMENTATION (FIGURE 13)

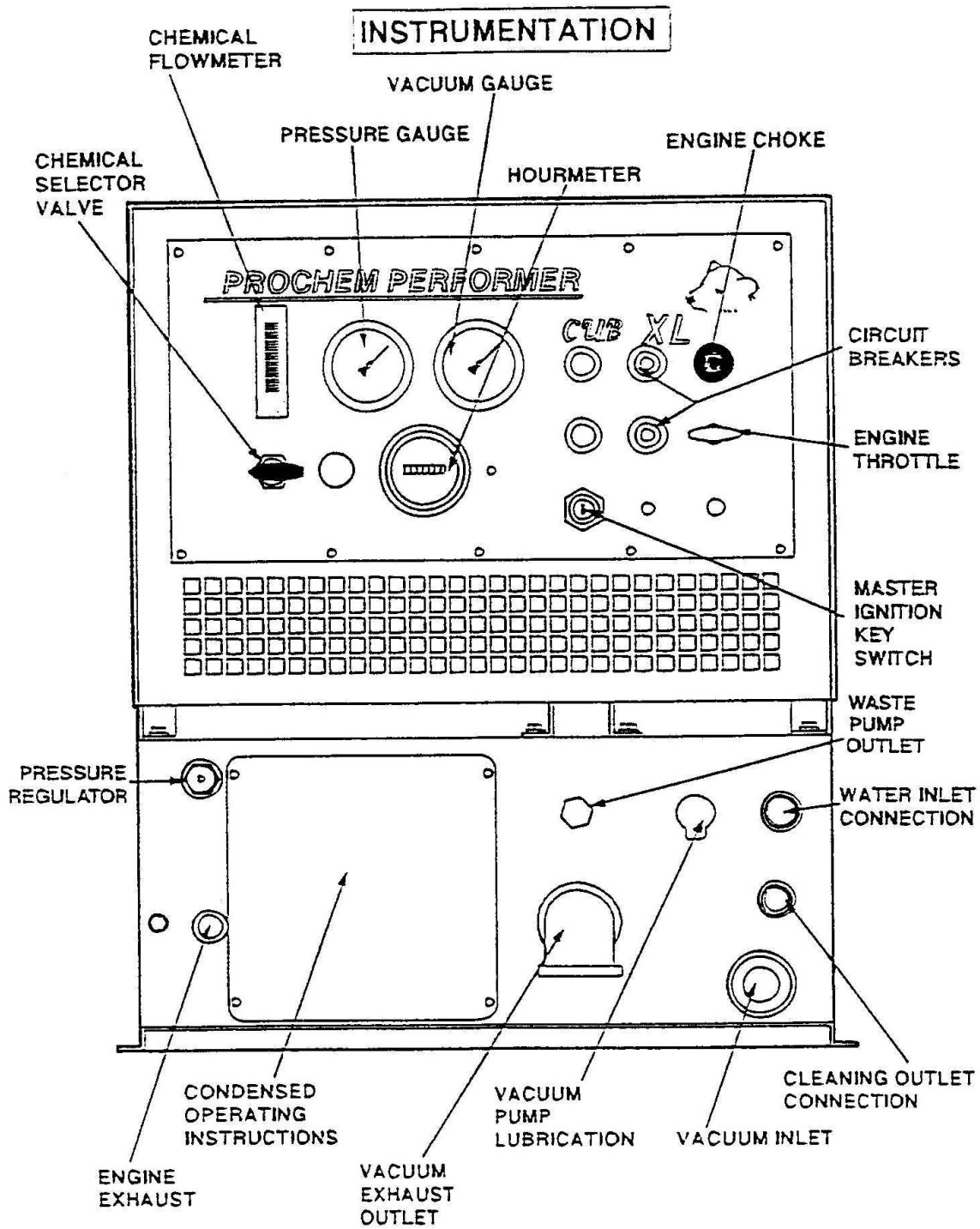

### 3 OPERATION

This chapter explains how to prepare, operate, shut down and daily maintain this unit. Operation of the *PERFORMER CUBXL CARPET CLEANER* is simple. However, only competent personnel who have had complete training should proceed.

**CAUTION:** This unit should NOT be operated inside a building or in any area where, in so doing, a violation of any Local, State, or Federal regulation(s) would be committed. It should only be operated in a well ventilated area because engine exhaust gases contain carbon monoxide.

#### 1. WATER SUPPLY CONNECTION:

**NOTE:** If using a water supply hose which has not been used recently or if using a customer's hose, connect the hose to the faucet only and turn the water on to flush out any debris which may be in the hose. Do this before connecting the hose to console.

- A. Connect the water supply hose to the water inlet connection.
- B. Connect the other end of your water supply hose to the water supply faucet.
- C. Turn the water supply faucet on. The water will fill the water tank.

#### 2. HOSE CONNECTIONS:

- A. Connect the pressure hose to the outlet connection at the front of the console and to the cleaning tool.
- B. Connect the vacuum hose to the cleaning tool and to the vacuum inlet connection at the front of the console.

3. **STARTING THE UNIT:** (figure 13, page 17)

**CAUTION:** DO NOT operate this unit without constant water flowing into the console. This may result in damage to the pump or other vital components.

- A. Turn the master switch on (the gas engine fuel pump will start operating).
- B. Start your engine.
  - 1. Pull the choke out.
  - 2. Turn the ignition key to start.
- C. After the engine is warmed up, push the choke in and turn the throttle counterclockwise. Then pull the throttle all the way out and turn it clockwise to lock it in the full throttle position. (This is the engine operating speed). (The engine operating speed is 3000 RPM with 100 feet of vacuum and pressure hose attached).

4. **PRIMING THE WATER PUMP:**

The water pump will prime itself when you start the engine. If the water pressure gauge reads 350 PSI when you open the cleaning wand, your pump is primed. If it does not, then refer to "LOSS OF WATER PUMP PRESSURE" in the troubleshooting section.

5. **PRIMING THE CHEMICAL PUMP:**

- A. While your unit is running, place the chemical feed line and the chemical prime tubing into the chemical container. **NOTE:** In placing the chemical feed tubing into the chemical, make sure that it is fully submerged since the chemical pump will NOT function if air is allowed to enter the chemical feed tubing.
- B. Turn the chemical valve on the front of the console to prime. This sets the chemical valve for priming. The chemical will then flow from the chemical container through the chemical feed tubing and back to the container through the chemical prime tube.

If the chemical does not flow:

- a. Remove the chemical prime tubing from the chemical container.

- b. Insert the prime tubing into the vacuum inlet at the front of the console. The vacuum will quickly pull the chemical from the chemical container.
  - c. When the chemical starts to flow, insert the chemical prime tube back into the chemical container.
- C. Once continuous chemical flow without air bubbles has been achieved, turn the chemical valve on the front of the unit to "CHEMICAL" and open cleaning tool. Then adjust the chemical metering valve located on the front of the chemical flowmeter to achieve the desired flow. For most purposes the average chemical flow rate is approximately two gallons per hour.

## 6. CLEANING:

Once you have completed steps 1 through 6, proceed to put the unit to work cleaning as follows:

- A. Before proceeding make sure the nozzle is functioning properly.
  - 1. To check, hold the wand about one foot above the surface to be cleaned and open the wand valve. A full spray should be observed from the cleaning nozzle.
  - 2. If the nozzle is not showing a full spray, clean or replace the nozzle.
- B. Normally, chemical is applied on the push stroke of the wand when cleaning, and vacuuming is done on the pull stroke. For heavily soiled carpets the wand may be used in a scrubbing manner, applying chemical in both the push and pull strokes. Always finish up an area with a vacuum pull stroke.

- C. When cleaning, keep the working opening (mouth) flat on the surface being cleaned. Keep the wand moving when the valve is open.
- D. The unit will automatically shut down when the waste tank contains approximately 44 gallons. This will prevent water being drawn into the vacuum pump.

**7. CLEANING SOLUTION HEAT:**

Heat for the cleaning solution is provided by pumping the water through an extremely efficient heat exchanger connected to the cleaning unit engine exhaust. In cases of long period of no solution flow (wand closed) a fixed thermostat will open a solenoid to bleed, water only, into the waste tank. On units which are so-equipped, an additional vacuum exhaust heat exchanger is provided to absorb heat from the vacuum pump exhaust.

**8. FLOOD RESTORATION:**

**CAUTION:** When doing flood restoration, attach the 36" convenience outlet hose to the solution outlet on the front of the console. Open the ball valve to release solution. This will prevent excessive heat in the water pumping system and allow the water box to fill, sending cool water into the water pump.

**9. STOPPING THE UNIT (and DAILY MAINTENANCE):**

- A. Turn the chemical valve on the instrument panel to the "OFF" position.
- B. At the end of each working day, allow the unit to run for 3 minutes with the vacuum hose disconnected in order to remove all moisture from the vacuum pump. Next, spray WD40 (or an equivalent) into the oil cup (on the front of the console) while the unit is running. This will lubricate the vacuum pump as well as protect the gears from rusting.
- C. Return the engine throttle to the IDLE position by pushing the throttle all the way in. Turn the ignition key to the "OFF" position.



- D. Unhook the cleaning tool, vacuum hose, and pressure hose. Place them in their storage spaces inside the vehicle.
- E. Turn the water supply faucet off. Bleed the pressure out of the water hose, unhook, and store the hose inside the vehicle.
- F. Drain the waste tank. **CAUTION:** DO NOT dump waste in any area which, in so doing, would violate any local, state, or federal law. Open the waste tank drain valve and allow to drain.
- G. Remove the strainer basket from the waste tank and clean out any accumulated debris. Re-install the strainer basket. Inspect the vacuum inlet filter in the waste tank. If there is any lint or debris, remove the filter and clean. When removing the filter, grip the plastic hexagonal section of the filter. Grasping the filter by the screen may collapse or ruin the filter. Re-install the filter, hand-tight.
- H. Rinse out the waste tank with fresh water. A small amount of "DUO®" (dual-action deodorizer) may be added to the waste tank to inhibit the growth of bacteria.
- I. Clean the unit, tools, hoses, van interior, etc., as needed. Inspect all equipment for any damage, wear, leaks, etc. Having a clean unit, which looks good cosmetically, provides a professional image to present customers and will attract future business as well.

#### 10. FREEZING PROTECTION:

If the unit is exposed to freezing weather, the water in the unit can freeze and may do serious damage to the unit. To avoid this, the following is recommended during the cold weather season:

- A. When the unit is not in use, always park it in a heated building.
- B. If a heated building is not available, provide a thermostatically controlled electric heater inside the vehicle.
- C. While in operation, avoid long shutdowns. Remember, the unit is providing heat while it is running. Shut it down just prior to leaving for the next job.

# WINTERIZING KIT INSTRUCTIONS

for Kit #66-945148 (p. 1 of 1)

## TO ADD ANTI FREEZE TO CONSOLE:

1. FILL WINTERIZING KIT TANK WITH 100% ANTI FREEZE SOLUTION. [USE ONLY GLYCOL BASE ANTI FREEZE]
2. CONNECT THE POWER CORD TO THE UNIT AS SHOWN BELOW.
3. CONNECT THE CONVENIENCE OUTLET HOSE TO THE SOLUTION OUTLET CONNECTION AT THE FRONT OF THE CONSOLE.
4. TURN UNIT ON AND SET THE ENGINE SPEED AT 'IDLE'. [FOR UNITS WHICH HAVE THE OPTION, THE WATER PUMP MUST BE 'ON'. SOLUTION WILL COME OUT OF THE CONVENIENCE OUTLET HOSE.]
5. ALLOW UNIT TO RUN UNTIL ALL WATER AND SOLUTION ARE PURGED FROM THE UNIT.
6. ATTACH ANTI FREEZE OUTLET HOSE TO THE WATER INLET CONNECTION AT THE FRONT OF THE CONSOLE.
7. FLIP THE WINTERIZING KIT SWITCH TO THE 'ON' POSITION.
8. SHUT THE UNIT & KIT DOWN WHEN ANTI FREEZE BEGINS TO FLOW OUT OF THE CONVENIENCE OUTLET HOSE
9. THE UNIT NOW CONTAINS ANTI FREEZE IN THE WATER SYSTEM PIPING AND HOSES.

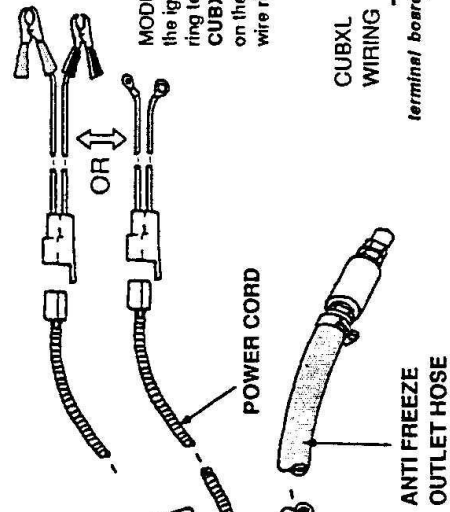
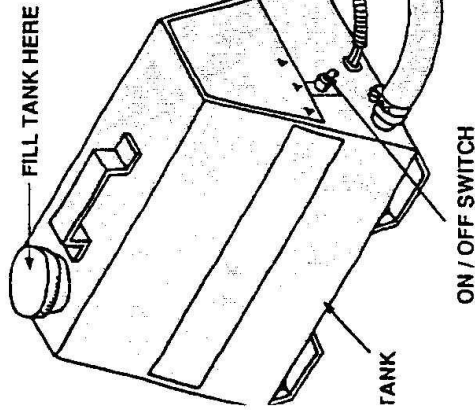

Using this cord, you may also connect directly to your unit's battery terminals.  
**red : positive terminal**  
**black : negative terminal**

**MODELS 800A & BRUIN:** Attach the red wire ring terminal to the ignition terminal on the ignition switch. Attach the black wire ring terminal to the control panel ground bolt.  
**CUBXL:** Attach the red wire ring terminal to the terminal board on the control panel as shown in diagram below. Attach the black wire ring terminal to the control panel ground bolt.

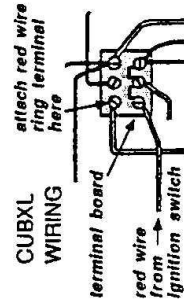

## TO REMOVE ANTI FREEZE FROM CONSOLE:

1. CONNECT THE CONVENIENCE OUTLET HOSE TO THE SOLUTION OUTLET CONNECTION AT THE FRONT OF THE CONSOLE.
2. INSERT THE END OF THE CONVENIENCE OUTLET HOSE IN THE WINTERIZING KIT TANK.
3. TURN UNIT ON AND SET THE ENGINE SPEED AT 'IDLE'. [FOR UNITS WHICH HAVE THIS OPTION, THE WATER PUMP MUST BE 'ON'.]
4. ANTI FREEZE WILL FLOW OUT OF THE HOSE INTO THE WINTERIZING KIT TANK. ALLOW UNIT TO RUN UNTIL THE FLOW OF ANTI FREEZE BECOMES A TRICKLE
5. CONNECT WATER SUPPLY HOSE TO THE CONSOLE WATER INLET CONNECTION AND WATER SUPPLY.
6. ALLOW THE ANTI FREEZE TO CONTINUE FLOWING UNTIL IT TURNS TO WATER. REMOVE THE CONVENIENCE OUTLET HOSE FROM THE TANK AND DISCONNECT IT FROM THE SOLUTION OUTLET.
7. CONNECT A HIGH PRESSURE HOSE WITH CLEANING TOOL TO THE CONSOLE SOLUTION OUTLET. OPEN THE CLEANING TOOL VALVE UNTIL ALL OF THE ANTI FREEZE IS FLUSHED OUT OF THE UNIT.

DISPOSAL OF USED ANTI FREEZE: OBSERVE LOCAL LAWS AND REGULATIONS. WHERE PERMITTED, WE RECOMMEND DISPOSAL IN SANITARY SEWER SYSTEMS. DO NOT DRAIN ON TO THE GROUND OR INTO STORM DRAINAGE SYSTEMS.

A minimum 50/50 mix of anti freeze and water will generally give freezing protection down to -34 degrees Fahrenheit. A 70/30 mix provides protection down to -47 degrees Fahrenheit. We recommend you use pure 100% anti freeze.

Cooling System Capacity - Quarts	QUARTS OF ANTI-FREEZE REQUIRED									
	4	5	6	7	8	9	10	11	12	13
8	-34	-70	-82	-84	-84	-84	-84	-84	-84	-84
9	-50	-50	-50	-50	-50	-50	-50	-50	-50	-50
10	-34	-34	-34	-34	-34	-34	-34	-34	-34	-34
11	-47	-47	-47	-47	-47	-47	-47	-47	-47	-47
12	-34	-34	-34	-34	-34	-34	-34	-34	-34	-34
13	-57	-57	-57	-57	-57	-57	-57	-57	-57	-57
14	-45	-45	-45	-45	-45	-45	-45	-45	-45	-45
15	-34	-34	-34	-34	-34	-34	-34	-34	-34	-34
16	-34	-34	-34	-34	-34	-34	-34	-34	-34	-34

Temperatures shown are shown in degrees Fahrenheit

## 4 GENERAL SERVICE ADJUSTMENTS:

### 1. PRESSURE REGULATOR:

The pressure regulator serves only to hold locked up water pressure at a preset point and to bypass this water back to the open tank. Adjust as follows:

- A. With your unit running, close the cleaning tool.
- B. Loosen lock nut, turn the adjusting nut until you reach the desired pressure. The normal factory setting is 350 PSI (50 PSI above the operating pressure).

### 2. ENGINE SPEED:

To adjust the engine RPM, refer to the *"Engine Operation and Service Manual"* for instructions. **CAUTION: DO NOT** attempt to adjust without a tachometer and **NEVER** adjust the engine above 3000 RPM.

### 3. FLOAT VALVE:

As the water supply pressure will vary, it may be necessary to adjust the float in the water tank to either increase or decrease the water tank level. To accomplish this, remove the water tank cover and loosen the thumb nut on the valve, adjust the float, then tighten the thumb nut and replace the cover.

### 4. VACUUM RELIEF VALVE:

While the unit is running at full RPM, block the air flow at the vacuum inlet connection and adjust the tension on the relief valve until it opens at 14 inches of mercury.

## 5 MAINTENANCE

To assure that your *PERFORMER CUBXL CARPET CLEANER* has a maximum life with a minimum of down time, we strongly advise that a **PLANNED PREVENTIVE MAINTENANCE PROGRAM** be initiated.

1. **GASOLINE ENGINE: CAUTION:** Major engine repairs should not be attempted unless you have the proper tools and a **THOROUGH** knowledge of internal combustion engines.
  - A. Check the engine oil level before starting and after every five (5) hours of operation. **BE SURE OIL LEVEL IS MAINTAINED. NEVER** over fill.
  - B. Change the crankcase oil after the first eight (8) hours of operation. Thereafter, change oil every twenty-five (25) hours of operation. **NOTE:** Refer to the *Engine Operation and Service Manual* for type and grade of oil.
  - C. Change oil filter every 50 hours of operation.
  - D. Remove and service the paper cartridge filter in the air cleaner yearly or every 100 hours (which ever comes first). Service the pre-cleaner every 3 months or 25 hours. Replace the cartridge when ever necessary. (Refer to *Engine Operation and Service Manual*).
  - E. Make sure that the cooling system is kept clean, clean yearly or every 100 hours, which ever comes first. (Refer to *Engine Operation and Service Manual*).
  - F. Clean and reset gap on spark plugs every 100 hours, if necessary, replace. **NOTE:** Never sandblast spark plugs. Spark plugs should be cleaned by scraping or wire brushing.
  - G. Replace in-line gas filter yearly.

**NOTE;** For additional engine service information, order # 272144 "*Vanguard Service and Repair Instructions*" from any authorized Briggs and Stratton Service Center. If service or repair is required, contact an authorized Briggs and Stratton Service Center. You will need model, type, and code number on the engine.

2. **VACUUM PUMP:** Refer to *Vacuum Pump Operation and Service Manual* for specific instructions.
  - A. Check the oil level daily to assure the proper level. **PROPER LEVEL** cannot be overemphasized. Too little oil will ruin bearings and gears. Too much oil will cause overheating.
  - B. Drain, flush and replace oil every 1500 hours or more frequently if inspection so indicates.
  - C. The bearing on the pulley end of the vacuum pump requires grease lubrication every 200 hours.
  - D. To prevent rust from building up inside the vacuum pump (if moisture exists) we have provided a lubrication cup on the front of the unit. First run the unit at least three minutes to remove any moisture from the vacuum pump. Next, fill the lubrication cup with WD40 or a similar lubricant while the unit is running and the vacuum inlet is sealed. Do this at the end of each working day.
  
3. **WATER PUMP:** Refer to the *Water Pump Operation and Service Manual* for specific instructions.
  - A. Check the oil level daily to assure the proper level.
  - B. After the first 200 hours, drain and refill the crankcase oil with 30 weight non-detergent oil.
  
4. **DRIVE BELTS:** The drive belts should be inspected daily. Check for loose belts, frayed belts, and mis-alignment. Correct any of these conditions, if damaged, replace.
  
5. **VACUUM TANK FILTER:** The vacuum filter should be removed and cleaned **DAILY**. If this is done, the filter will last for a long period of time. Replace this filter at least once a year.
  
6. **BATTERY:** Check the fluid level in the battery once a week. If low, fill to the proper level with distilled water.

7. **HEAT EXCHANGER:** Proper and consistent heat exchange is a product of a well maintained engine. If an engine is not properly maintained the exhaust gases will deposit carbon on the outside of the heat exchanger coil and continuous running will affect the cleaning solution temperature. If this condition exists, remove the heat exchanger from the unit and clean the carbon off the coil. Using A212 ULTRACLEAN INDUSTRIAL CLEANER will greatly enhance the removal of carbon deposits. Plug one end of the heat exchanger and fill the heat exchanger with a mixture of one part of A212 to four parts of warm water. Allow one hour of soaking, then drain and rinse with hot water. If necessary, repeat. Unplug the condensation drain tube every 250 hours, or monthly.

PRESSURE REGULATOR O-RING LUBRICATION

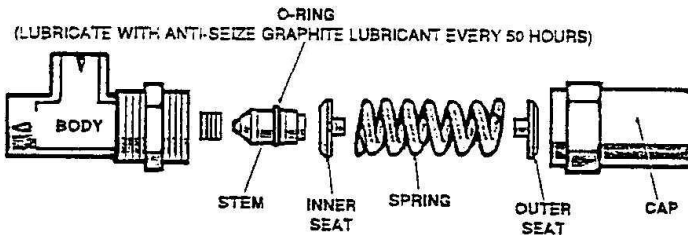

FOR BEST RESULTS WITH THE SUTTNER PRESSURE REGULATORS, WE RECOMMEND THAT YOU LUBRICATE THE O-RING WITH AN ANTI-SEIZE TYPE GRAPHITE LUBRICANT EVERY 50 HOURS OR WHEN REQUIRED.

THIS MAY BE DONE CONVENIENTLY BY FIRST REMOVING THE CAP, OUTER SEAT, SPRING, AND INNER SEAT WITH THE UNIT OFF. NEXT, WHILE HOLDING THE PALM OF YOUR HAND IN FRONT OF THE PRESSURE REGULATOR, START YOUR UNIT. THE STEM WITH THE O-RING WILL POP INTO YOUR HAND. AFTER LUBRICATING, RE-ASSEMBLE. *IT'S THAT SIMPLE.*

THIS WILL PREVENT THE STEM FROM STICKING.

## 6 COMPONENT REPAIR:

The following general instructions are for the repair of various components. ONLY FULLY TRAINED personnel should repair components.

1. **VACUUM PUMP:**

Refer to the *Vacuum Pump Operation and Service Manual*.

2. **GASOLINE ENGINE:**

Refer to the *Engine Operation and Service Manual*. If more detail is needed, you should procure a 272144 Service and Repair Book from a local authorized Briggs and Stratton Service Center.

3. **WATER PUMP:**

Refer to *Water Pump Operation and Service Manual*.

## 7 TROUBLESHOOTING

Before proceeding, you can save time by checking:

- A. That the engine speed is 3000 RPM with the throttle pulled all the way out.
- B. That the water supply is turned on.
- C. That the pump volume is correct. Check pump volume with your cleaning tool closed. Measure the water flow going back to the water tank directly from the pressure regulator. You should fill a gallon container in 20 seconds.

### SPECIFIC PROBLEMS:

1. **LOSS OF WATER PUMP PRESSURE:** With the cleaning tool open, the water pressure gauge reads below the normal operating pressure.

PROBABLE CAUSES	CORRECTIVE ACTION
Water supply is turned off, or the float valve is improperly adjusted or stuck.	Turn the water supply on or up. Check for kinks in the water supply hose. Examine the float valve and adjust or replace. One gallon of water should be maintained in the water box.
Water inlet line plugged or drawing air.	Examine the water inlet filter inside the water box. Remove any excessive debris and replace, if required. Check for suction leaks and loose clamps or fittings. Tighten any loose fittings or clamps. Replace any ruptured hose.
Water pressure regulator dirty, stuck open, improperly adjusted, has worn seals, or is not seated properly.	Clean or repair water pressure regulator and adjust to 50 PSI above working pressure. If necessary, replace.
Improper engine speed.	Re-adjust engine speed to 3000 RPM. See <i>Briggs and Stratton Operation and Service Manual</i> .



PROBABLE CAUSES	CORRECTIVE ACTION
Low pump volume (check pump volume by closing the cleaning tool and measuring the amount of water being returned to the water tank by the pressure regulator. It should fill a gallon container in 20 seconds).	Examine the check valve assemblies in the water pump. Clean out or replace. (Refer to <i>Pump Operation and Service Manual</i> .)
Defective pressure gauge.	Replace gauge.
Orifice in cleaning tool worn or wrong.	Replace orifice.
Bleed solenoid stuck open or defective.	Clean seat in solenoid valve. Replace solenoid.

2. **LOSS OF WATER PUMP VOLUME:** With the cleaning tool open, a reduction in water volume through the tool. Pressure gauge reads normal.

PROBABLE CAUSES	CORRECTIVE ACTION
Plugged orifice in the cleaning tool.	Unplug orifice.
Cleaning tool valve is malfunctioning.	Repair or replace valve.
Defective quick-connect.	Replace defective quick-connect on high pressure hose.
"Y" strainer on unit plugged.	Clean or replace the strainer screen.
Outlet check valve is dirty, improperly seated, or the cage is improperly installed.	Examine the check valve and remove any debris. Inspect for complete seating. Repair or replace.

3. **LOSS OF VACUUM:** While cleaning, the vacuum is not up to par. Engine RPM is normal.

PROBABLE CAUSES	CORRECTIVE ACTION
Vacuum hose(s) is damaged, causing a suction leak.	Inspect the vacuum hose(s). Repair any damage or replace.
Waste tank gasket not sealing properly, causing a suction leak.	Inspect the gasket. Repair seal or replace.
Plugged vacuum line.	Unplug or repair the vacuum line.
Waste tank filter is plugged.	Clean or replace filter.
Loose vac pump drive belt.	Tighten the drive belt.
Waste tank drain valve is damaged, causing a suction leak.	Drain the waste tank. Remove the dump valve and, after inspecting, replace the defective components.
Vacuum relief has a suction leak.	Re-adjust the vacuum relief valve. If the vacuum does not increase, remove and inspect the relief valve diaphragm. If damaged, replace.
Vacuum pump is worn out.	Replace the vacuum pump.
Vacuum exhaust heat exchangers are plugged with lint.	Remove and clean.

4. **LOSS OF CHEMICAL:** With the cleaning tool valve open, no chemical.

PROBABLE CAUSES	CORRECTIVE ACTION
Chemical pump is improperly primed.	Refer to "Chemical pump priming instructions."
The strainer at the inlet end of the chemical inlet line is clogged.	Unclog the strainer, if damaged, replace.
Suction leak in the inlet line leading into the chemical pump.	Inspect inlet lines and flow meter for damage and replace, if required.
Chemical check valve(s) is clogged or has damaged o-ring(s).	Remove any debris from the chemical chemical check valve(s). Replace damaged o-ring(s) or entire chemical check valve(s) if necessary.
Chemical prime/on-off valve or chemical metering valve is defective.	Replace valve(s).
Chemical pump diaphragm is ruptured.	Disassemble the chemical pump and replace the damaged diaphragm.
Defective cylinder in the water pump.	Measure the pump volume. If the pump volume is less than normal, refer to "Loss of pump volume" section in this manual.

5. **ENGINE WILL NOT START:** During the normal start-up, the engine will either not start or will not turn over.

PROBABLE CAUSES	CORRECTIVE ACTION
Circuit breaker tripped on hot line to the master switch.	Reset circuit breaker.
Waste tank is full.	Empty the waste tank.
Defective key switch.	Replace switch.
Defective starter solenoid.	Replace starter solenoid.
Defective gas engine fuel pump.	Replace fuel pump.

PROBABLE CAUSES	CORRECTIVE ACTION
Vacuum pump frozen (If the pump impellers are rusted, then the engine will stall).	Free the vacuum pump. Refer to <i>Vacuum Pump Operation and Service Manual</i> .
Dead battery.	Recharge or replace battery.
Malfunction of the gasoline engine.	Repair engine. Refer to <i>Engine Operation and Service Manual</i> .

6. **ENGINE STOPS RUNNING:** While doing normal carpet cleaning, the engine stops running.

PROBABLE CAUSES	CORRECTIVE ACTION
Loss of oil pressure.	Check oil level, oil filter and oil pressure switch.
Waste tank full or defective float switch.	Drain waste tank or replace float switch.
Malfunction of the gasoline engine.	Repair engine. Refer to <i>Engine Operation and Service Manual</i> .
Defective fuel pump.	Check wiring, if intact replace fuel pump.
Defective anti-diesel solenoid.	Check wiring, if intact replace anti-diesel solenoid.

7. **LOSS OF TEMPERATURE:** The heat output of the unit is LESS than normal.

PROBABLE CAUSES	CORRECTIVE ACTION
Heat bypass valve on the control panel is open further than necessary.	Close the temperature control valve by turning the knob clockwise.
Defective temperature gauge.	If defective, replace.

PROBABLE CAUSES	CORRECTIVE ACTION
Defective engine thermostat which is stuck in the open position.	If defective, replace.
Thermal valve in water box is defective or stuck.	Clean unit and test. If defective, replace.
Solenoid valve is stuck open.	Check hi-temperature sensor at heat exchanger. Disassemble and check for residue.
Engine RPM is low.	Reset engine RPM, refer to " <i>Engine Operation and Maintenance Manual</i> ".
Damaged or plugged radiator core in vac preheater.	Remove and inspect cores, replace if defective.
Heat exchanger is carbon coated on outside of coil.	Soak coil section at a radiator shop. Boil tank or soak in PROCHEM Ultraclean Industrial (A212).
Heat exchanger is scaled on inside of coil.	Descale coil using E521 "Inhibited Descaler". See Maintenance section #12.

8. **CHEMICAL FLOWMETER INDICATES FLOW WITH THE CLEANING TOOL VALVE CLOSED:**

PROBABLE CAUSES	CORRECTIVE ACTION
Chemical pump diaphragm is ruptured.	Close the chemical valve on the instrument panel. If the flowmeter still indicates flow, examine the water which is bypassing from the pressure regulator to the water tank. If there is chemical in this water, replace the chemical pump diaphragm.
Spring weak or defective in 1/2" check valve.	Replace check valve spring.

# CUBXL WIRING DIAGRAM

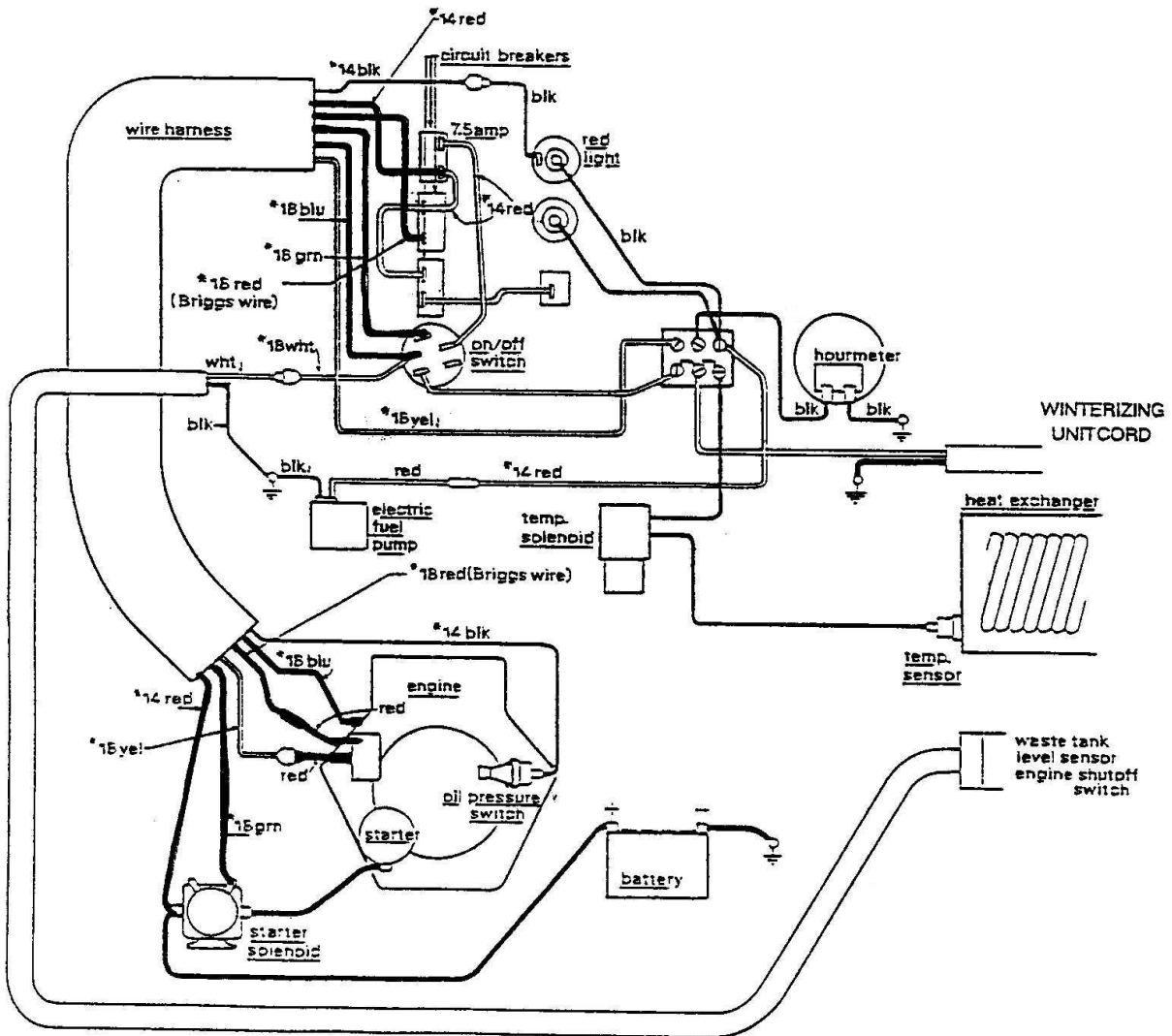

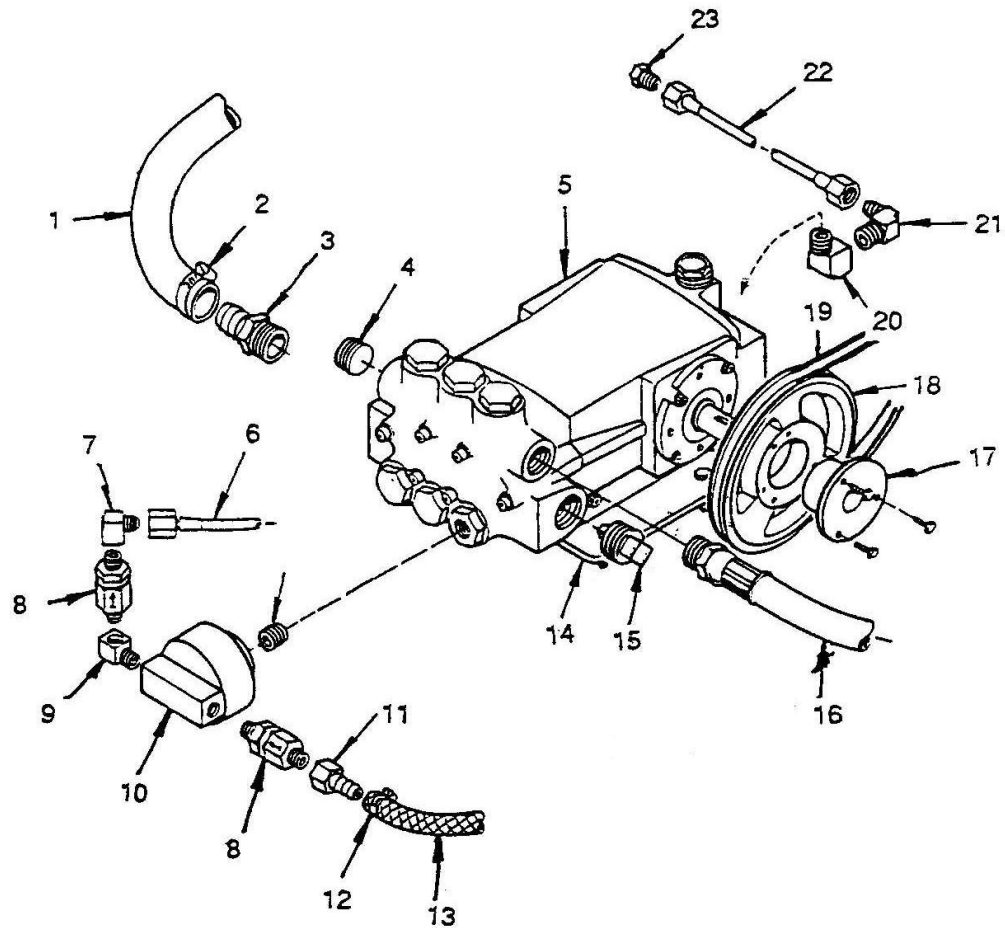

- |    |           |                             |    |           |                         |
|----|-----------|-----------------------------|----|-----------|-------------------------|
| 1  | 09-805331 | HOSE, 5/8 X 6"              | 16 | 10-805228 | HOSE, 3/8 X 19-1/4"     |
| 2  | 03-000113 | HOSE CLAMP                  | 17 | 44-802204 | HUB, WATER PUMP         |
| 3  | 12-800269 | BARB FITTING, 1/2P X 5/8H   | 18 | 44-802205 | PULLEY, WATER PUMP      |
| 4  | 11-800224 | PLUG, 3/8                   | 19 | 44-802215 | BELT, WATER PUMP        |
| 5  | 41-809061 | WATER PUMP                  | 20 | 11-800045 | STREET ELBOW, 1/4       |
| 6  | 10-805289 | SST HOSE, 3/16 X 27-1/2"    | 21 | 12-800031 | ELBOW, 1/4P X 1/4T      |
| 7  | 12-800142 | ELBOW, 1/8FP X 1/4T         | 22 | 10-805130 | SST HOSE, 3/16 X 13-1/2 |
| 8  | 15-808030 | CHECK VALVE                 | 23 | 12-800029 | PLUG, 1/4T              |
| 9  | 11-800014 | STREET ELBOW, 1/8           |    |           |                         |
| 10 | 41-809044 | CHEMICAL PUMP               |    |           |                         |
| 11 | 12-800098 | BARB FITTING, 1/8FP X 5/16H |    |           |                         |
| 12 | 03-000065 | HOSE CLAMP                  |    |           |                         |
| 13 | 09-805309 | HOSE, 5/16 X 30"            |    |           |                         |
| 14 | 56-501682 | MOUNT, WATER PUMP           |    |           |                         |
| 15 | 11-800168 | PLUG, 1/2                   |    |           |                         |

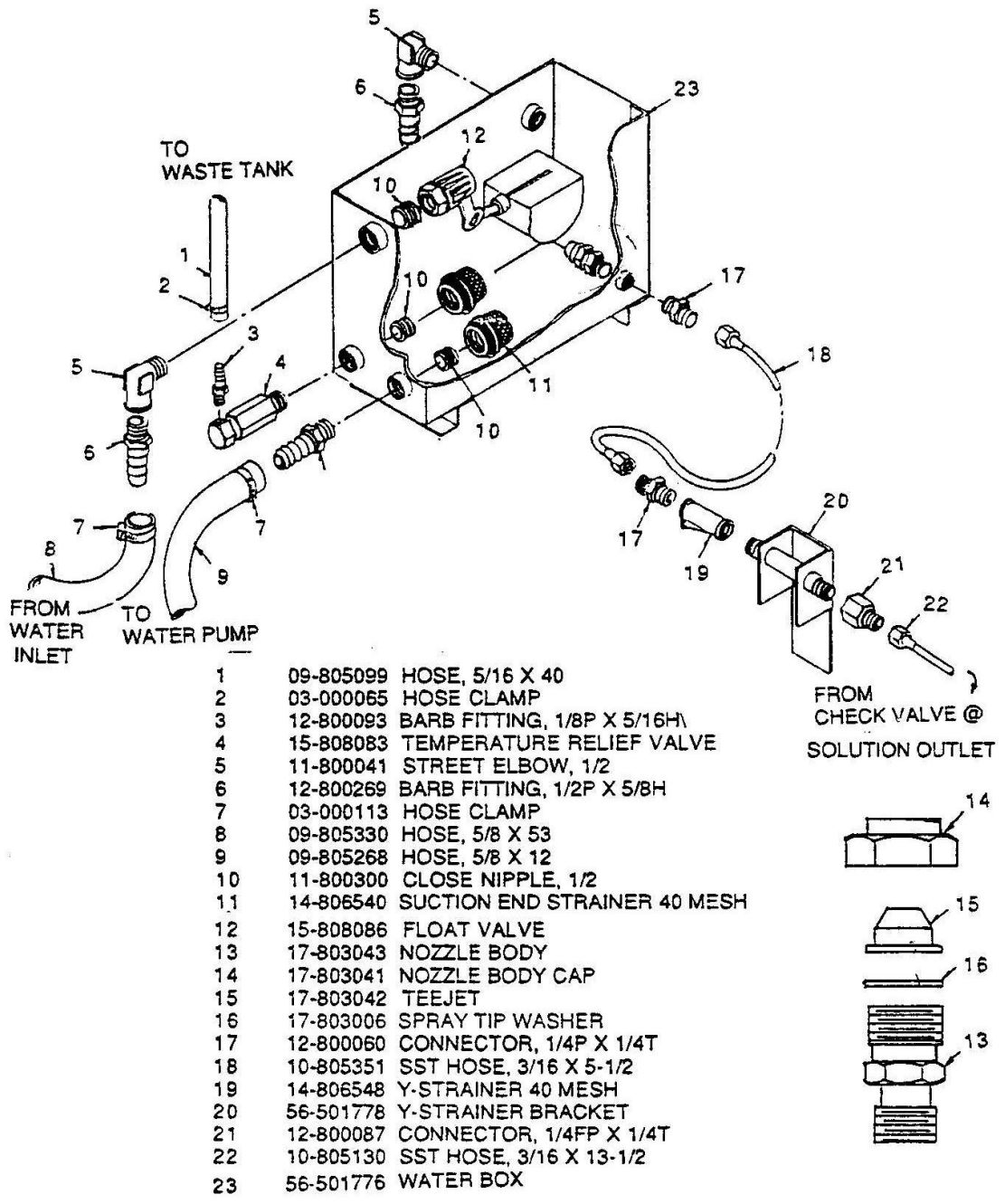

- 1 09-805099 HOSE, 5/16 X 40
- 2 03-000065 HOSE CLAMP
- 3 12-800093 BARB FITTING, 1/8P X 5/16H
- 4 15-808083 TEMPERATURE RELIEF VALVE
- 5 11-800041 STREET ELBOW, 1/2
- 6 12-800269 BARB FITTING, 1/2P X 5/8H
- 7 03-000113 HOSE CLAMP
- 8 09-805330 HOSE, 5/8 X 53
- 9 09-805268 HOSE, 5/8 X 12
- 10 11-800300 CLOSE NIPPLE, 1/2
- 11 14-806540 SUCTION END STRAINER 40 MESH
- 12 15-808086 FLOAT VALVE
- 13 17-803043 NOZZLE BODY
- 14 17-803041 NOZZLE BODY CAP
- 15 17-803042 TEEJET
- 16 17-803006 SPRAY TIP WASHER
- 17 12-800060 CONNECTOR, 1/4P X 1/4T
- 18 10-805351 SST HOSE, 3/16 X 5-1/2
- 19 14-806548 Y-STRAINER 40 MESH
- 20 56-501778 Y-STRAINER BRACKET
- 21 12-800087 CONNECTOR, 1/4FP X 1/4T
- 22 10-805130 SST HOSE, 3/16 X 13-1/2
- 23 56-501776 WATER BOX

FROM  
CHECK VALVE @  
SOLUTION OUTLET

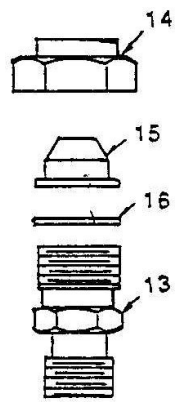



# PRESSURE REGULATOR PARTS

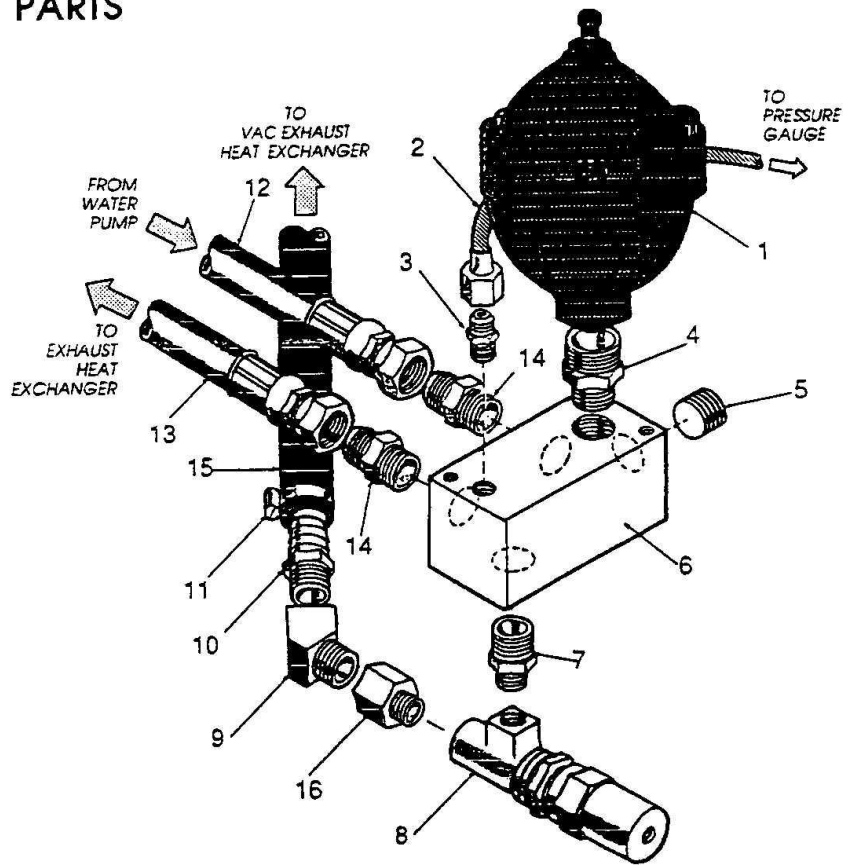

- 1 41-809016.....PULSATION DAMPER
- 2 10-805130.....HOSE, 3/16SST X 10-1/2"
- 3 12-800065.....CONNECTOR, 1/8P X 1/4T
- 4 11-800023.....HEX NIPPLE, 1/2 X 3/8
- 5 11-800224.....PLUG, 3/8
- 6 52-501603.....MANIFOLD
- 7 11-800381.....SST NIPPLE, 3/8 X 1/4 SST
- 8 15-808081.....PRESSURE REGULATOR
- 9 11-800341.....STREET ELBOW, 3/8 45°
- 10 12-800345.....BARB FITTING, 3/8P X 5/8H
- 11 03-000113.....HOSE CLAMP
- 12 10-805228.....HOSE, 3/8 X 19"
- 13 10-805275.....HOSE, 3/8 X 19"
- 14 12-800282.....CONNECTOR, 3/8P X 1/2T
- 15 09-805322.....HOSE, 5/8 X 36"
- 16 11-800090.....CONNECTOR, 3/8FP X 1/4P

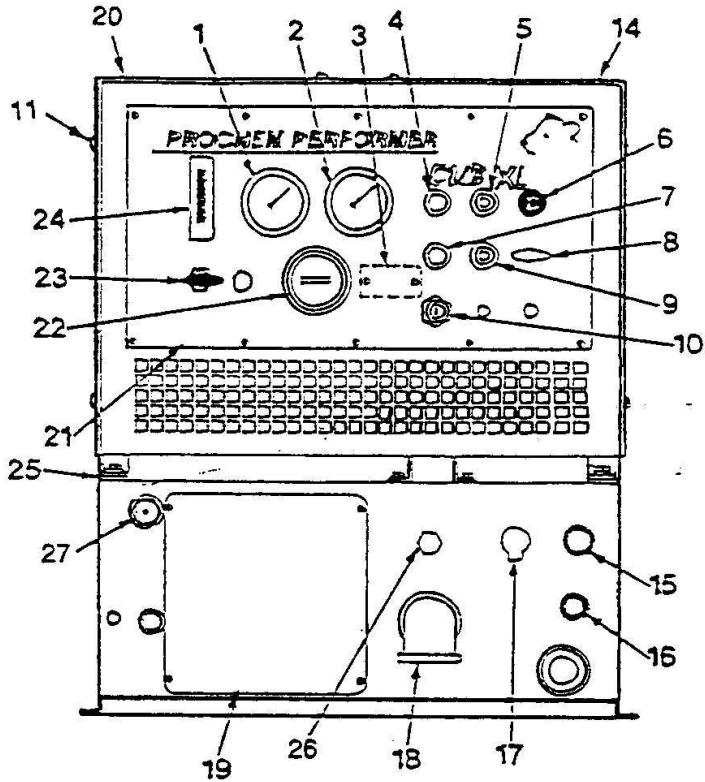

1	18-808506	GAUGE, WATER PRESSURE	14	61-950475	RIGHT HOOD ASSY
2	18-808519	GAUGE, VACUUM	15	13-806008	DISCONNECT, 3/8F
3	33-900168	TERMINAL BOARD	16	13-806001	DISCONNECT, 1/4F
4	34-900039	LIGHT, RED	17	19-800075	LUBRICATION CUP
5	33-900164	CIRCUIT BREAKER, 7.5 AMP	18	11-800359	ELBOW, 1-1/2 45 DEG
5A	33-900162	PLATE, RESET	19	50-501601	PLATE, INSTRUCTION
6	49-802518	CHOKE CABLE	20	61-950476	LEFT HOOD ASSY
7	34-900094	LIGHT, GREEN	21	50-501648	CONTROL PANEL
8	49-802505	THROTTLE CABLE	22	34-903000	HOURMETER
9	33-900163	CIRCUIT BREAKER, 20 AMP	23	15-808022	CHEMICAL VALVE
9A	33-900162	PLATE, RESET	24	18-808513	FLOW METER
10	32-900174	SWITCH, IGNITION	25	58-700024	VIBRATION PAD
11	00-000272	1/4 TURN LATCH	26	11-800019	CAP, 1/2
12	02-000268	RETAINER WASHER	27	15-808081	PRESSURE REGULATOR
13	01-000259	FASTENER, TURN LATCH			

**NOT SHOWN**

15-808029 DUMP VALVE

66-945134 TEMP REDUCTION KIT

VACUUM SYSTEM PARTS LISTING

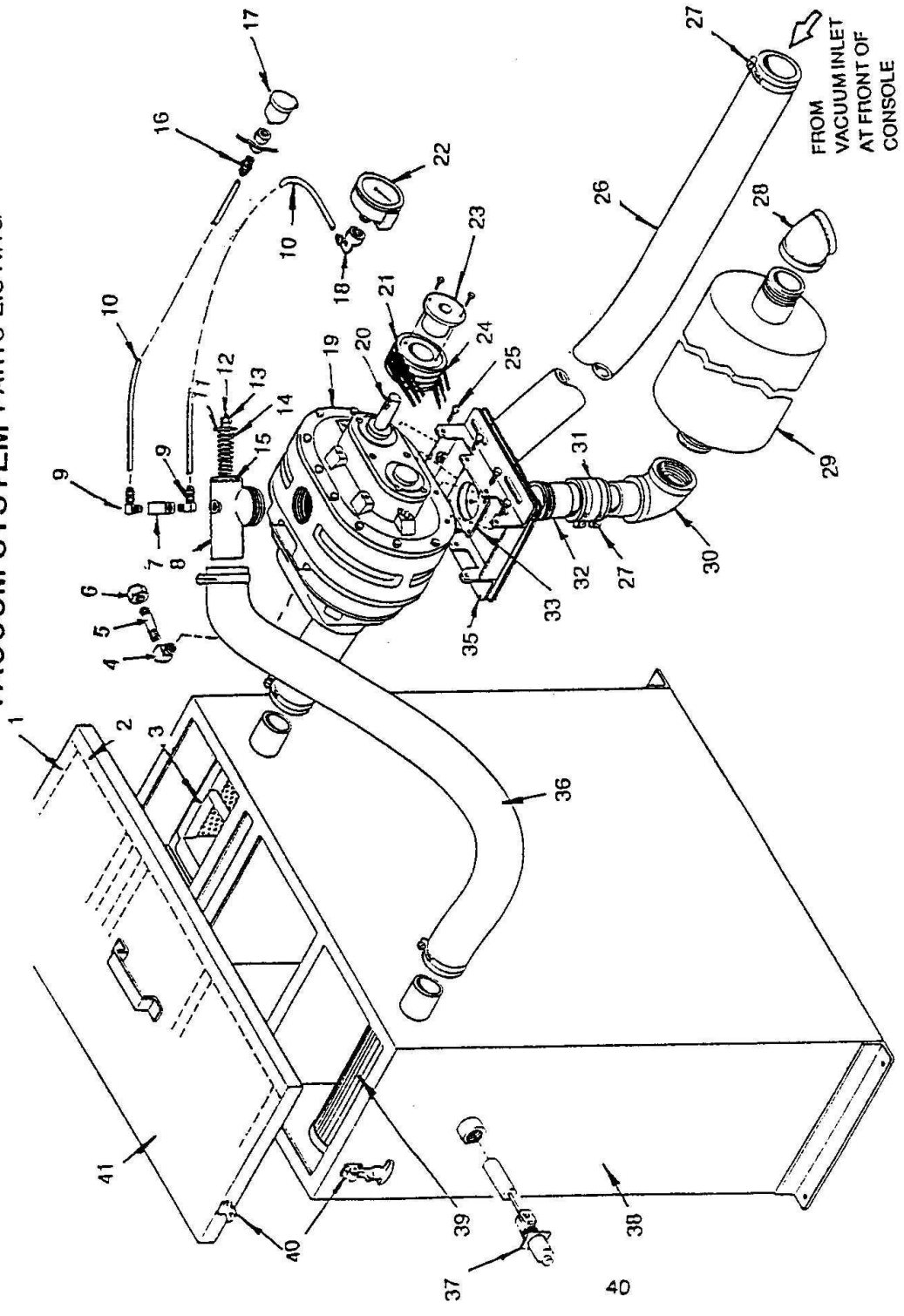

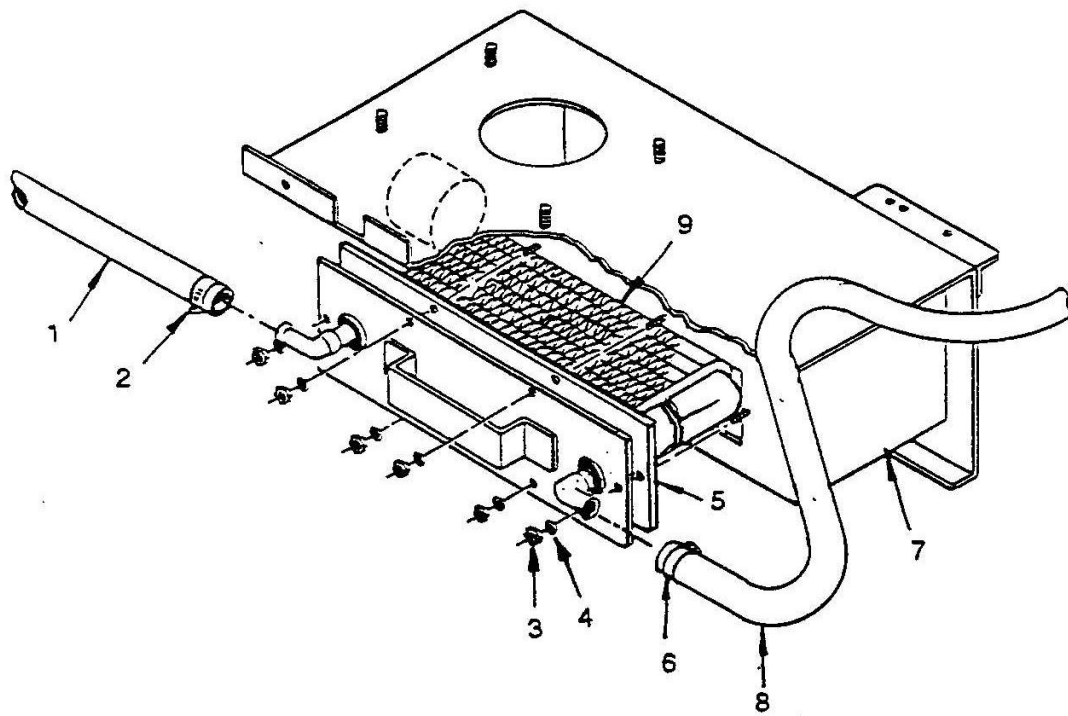

- 1 09-805322 HOSE, 5/8 X 36
- 2 03-000113 HOSE CLAMP
- 3 01-000057 NUT
- 4 02-000038 LOCKWASHER
- 5 43-807078 GASKET
- 6 03-000113 HOSE CLAMP
- 7 56-501638 BODY
- 8 09-805228 HOSE, 5/8 X 27"
- 9 57-520055 HEAT EXCHANGER

## ENGINE ASSEMBLY PARTS

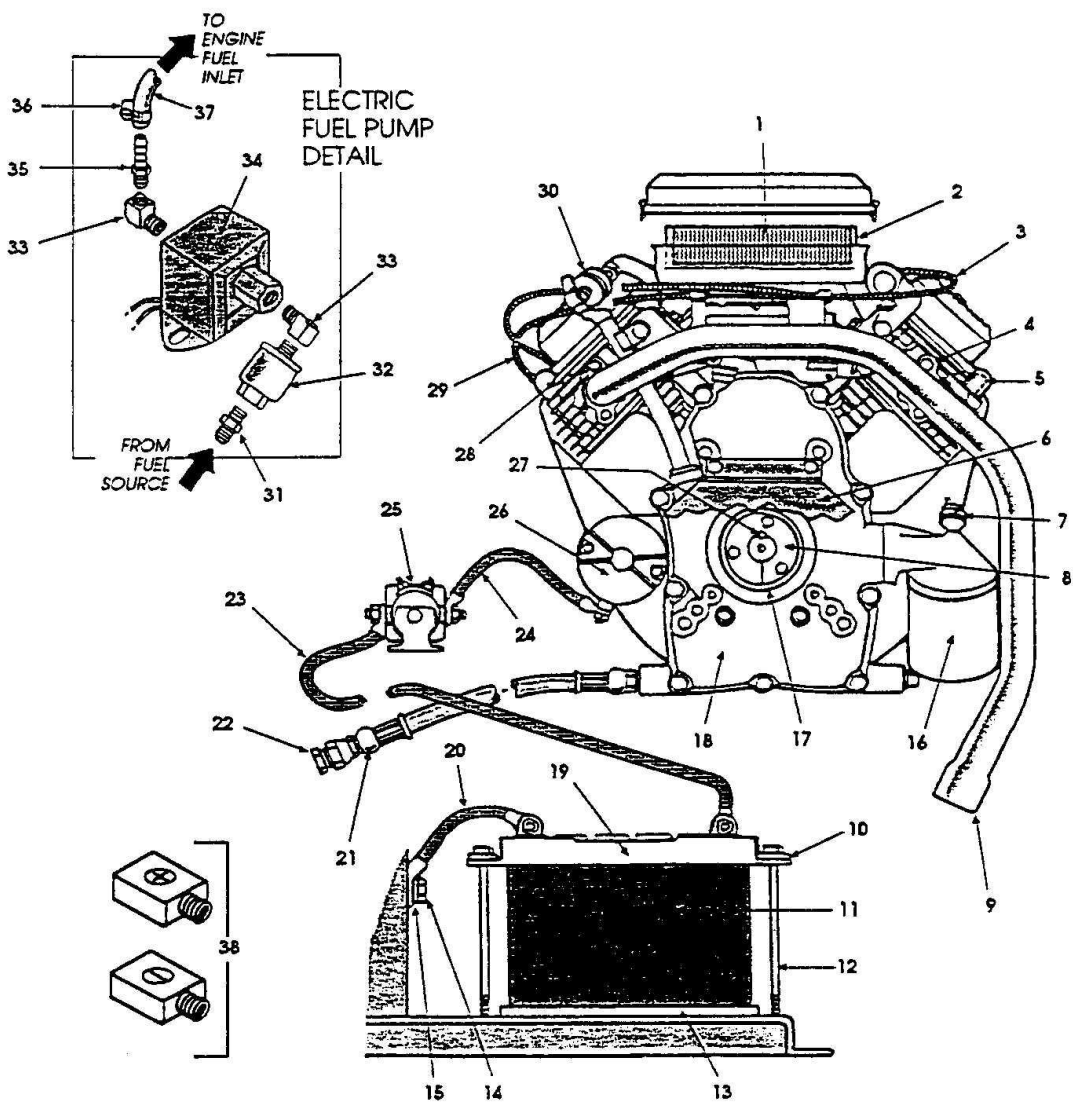

- |    |  |    |  |
|----|--|----|--|
| 1  | 42-902005.....CARTRIDGE, AIR CLEANER   | 20 | 64-950060.....BATTERY CABLE x 8'               |
| 2  | 42-902006.....ELEMENT, AIR CLEANER     | 21 | 10-805291.....HOSE, OIL DRAIN                  |
| 3  | 49-802518.....CHOKE CABLE              | 22 | 12-800062.....PLUG, OIL DRAIN                  |
| 4  | 42-902174.....GASKET, EXHAUST MANIFOLD | 23 | 64-950491.....BATTERY CABLE x 37'              |
| 5  | 42-902169.....SPARK PLUG               | 24 | 64-950456.....BATTERY CABLE x 14'              |
| 6  | 56-501630.....BELT GUARD               | 25 | 35-901002.....STARTER SOLENOID                 |
| 7  | 35-900169.....OIL PRESSURE SWITCH      | 26 | 42-902176.....STARTER MOTOR                    |
| 8  | 44-802202.....HUB, ENGINE              | 27 | 54-500412.....KEY, ENGINE                      |
| 9  | 56-501613.....EXHAUST TUBE             | 28 | 42-902168.....GASKET VALVE COVER               |
| 10 | 02-000066.....FLATWASHER, 1/4          | 29 | 49-802505.....THROTTLE CABLE                   |
| 11 | 36-900056.....BATTERY                  | 30 | 42-902172.....FUEL FILTER, ENGINE              |
| 12 | 00-000167.....SCREW, 1/4-20 x 6"       | 31 | 12-800067.....CONNECTOR, 5/16 INV FLARE x 1/4T |
| 13 | 47-700007.....HEAT SHIELD              | 32 | 14-806542.....FUEL FILTER                      |
| 14 | 01-000037.....NUT, 1/4-20              | 33 | 11-800014.....STREET ELBOW, 1/8                |
| 15 | 02-000038.....LOCKWASHER, 1/4          | 34 | 41-809003.....ELECTRIC FUEL PUMP               |
| 16 | 42-902158.....OIL FILTER               | 35 | 12-800041.....BARB FITTING, 1/8P x 1/4H        |
| 17 | 44-802203.....SHEAVE, ENGINE           | 36 | 03-000065.....HOSE CLAMP                       |
| 18 | 61-950458.....ENGINE                   | 37 | 09-805351.....FUEL HOSE, 1/4 x 7-1/4'          |
| 19 | 56-500188.....HOLD-DOWN, BATTERY       | 38 | 31-900179.....TERMINAL PROTECTORS (1 pair)     |

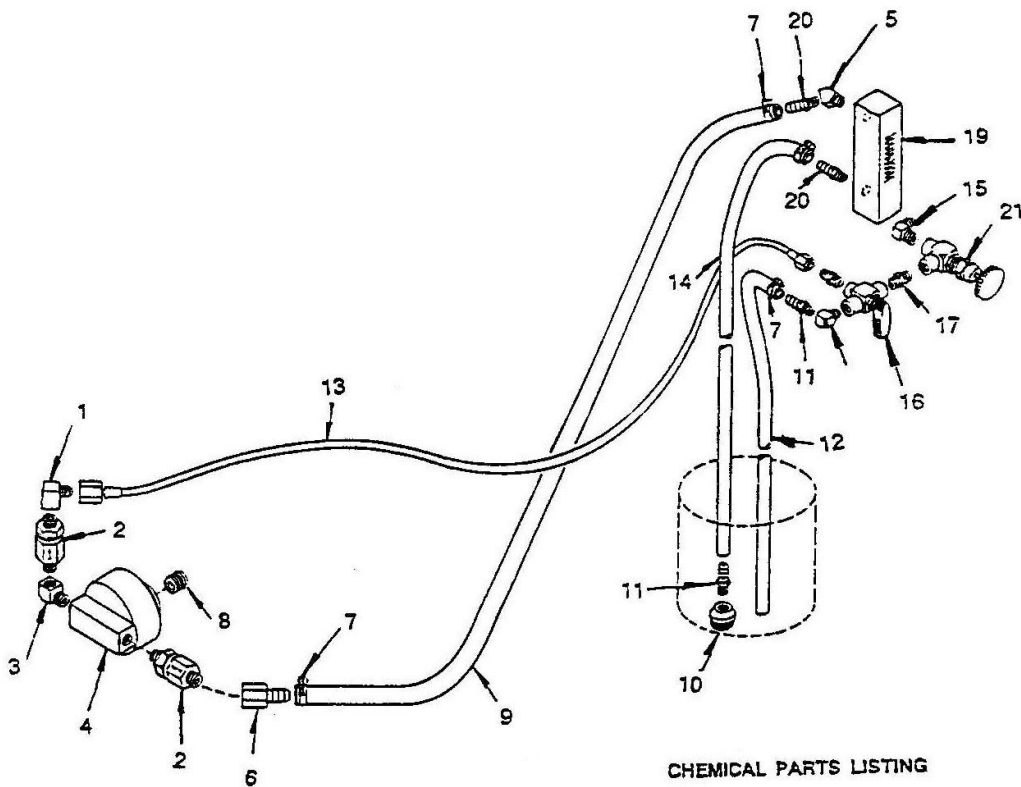

**CHEMICAL PARTS LISTING**

- 1 12-800142 ELL 1/8FP x 1/4T
- 2 15-808030 CHEMICAL CHECK VALVE
- 3 11-800014 ST. ELBOW, 1/8
- 4 41-809044 CHEMICAL PUMP
- 5 11-800112 ST. ELBOW, 1/8 45 DEG
- 6 12-800098 BARB FITTING, 1/8FP X 5/16H
- 7 03-000085 HOSE CLAMP
- 8 11-800369 CLOSE NIPPLE, 1/4 SST
- 9 09-805309 HOSE, 5/16 X 30"
- 10 14-805508 END STRAINER
- 11 12-800093 BARB FITTING, 1/8P X 5/16H
- 12 09-805099 VINYL TUBING, 5/16 X 40"
- 13 10-805142 SST HOSE, 3/16 X 29"
- 14 09-805099 VINYL TUBING, 5/16 X 40"
- 15 12-800040 ELL 1/8P X 1/4T
- 16 15-808022 CHEMICAL VALVE
- 17 11-800022 NIPPLE, HEX 1/8
- 18 10-805131 SST HOSE, 3/16 X 20-1/2"
- 19 18-808513 FLOMETER
- 20 12-800093 BARB FITTING, 1/8P X 5/16H
- 21 15-808087 METERING VALVE

## WATER PUMP DETAIL PARTS LISTING

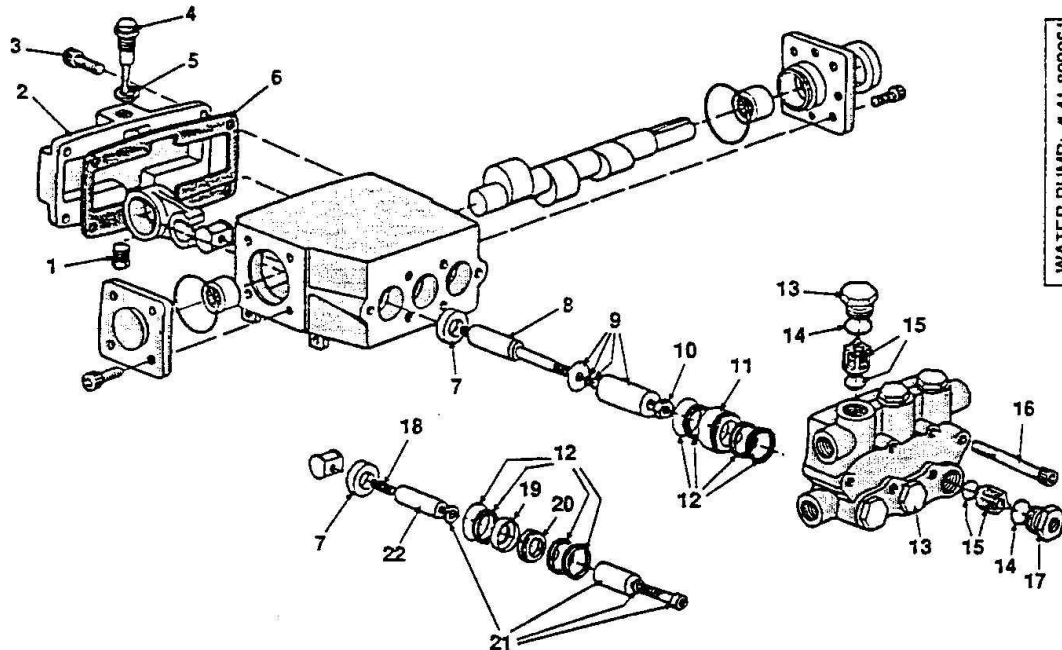

### PARTS LISTING

- |    |                |                             |
|----|----------------|-----------------------------|
| 1  | 11-800220..... | PLUG                        |
| 2  | 42-809170..... | COVER                       |
| 3  | 00-000140..... | SCREW, R. COVER             |
| 4  | 42-809171..... | DIPSTICK                    |
| 5  | 42-809102..... | GASKET                      |
| 6  | 43-810060..... | GASKET, COVER               |
| 7  | 42-809198..... | OIL SEAL                    |
| 8  | 42-809199..... | LOWER PLUNGER [2345B]       |
| 9  | 42-809196..... | PLUNGER KIT [2345B]         |
| 10 | 42-809200..... | RETAINING NUT [2345B]       |
| 11 | 42-809201..... | CUP RETAINER [2345B]        |
| 12 | 42-809216..... | PLUNGER SEAL KIT            |
| 13 | 42-809206..... | CAP, CHECK VALVE            |
| 14 | 43-810046..... | O-RING                      |
| 15 | 42-809165..... | VALVE KIT                   |
| 16 | 00-000037..... | SCREW                       |
| 17 | 42-809209..... | CAP, CHECK VALVE [1/4 FNPT] |
| 18 | 42-809106..... | STUD                        |
| 19 | 42-809203..... | CUP RETAINER [8745B]        |
| 20 | 42-809202..... | SPACER [8745B]              |
| 21 | 42-809105..... | PLUNGER KIT [8745B]         |
| 22 | 42-809107..... | LOWER PLUNGER [8745B]       |
| 23 | 42-809204..... | PLUNGER CONVERSION KIT      |
- [from 8745 to 2345] Includes connecting rod, wrist pin, lower plunger[ref.#8], plunger kit[ref.#9], and retaining nut[ref.#10].

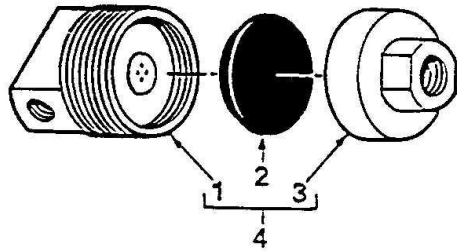

- 1 42-809046 BODY
- 2 42-809047 DIAPHRAGM
- 3 42-809045 COVER
- 4 41-809044 CHEMICAL PUMP
- 5 43-810022 O-RING
- 6 16-808182 SPRING
- 7 16-808181 WASHER
- 8 15-808030 CHEMICAL CHECK VALVE
- 9 41-809016 PULSATION DAMPER
- 10 42-809026 CAP
- 11 43-810012 O-RING
- 12 42-809028 CHECK VALVE
- 13 42-809029 DIAPHRAGM
- 14 42-809030 BAFFLE PLUG

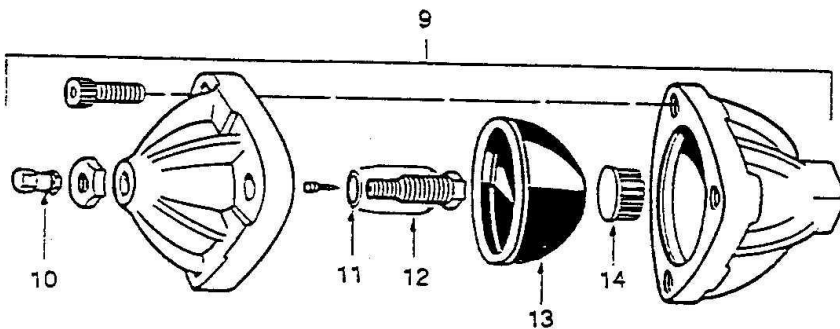
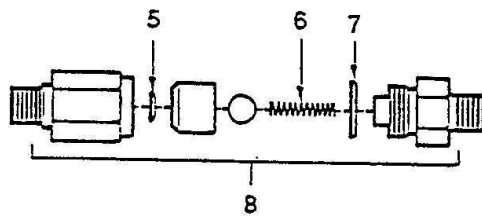



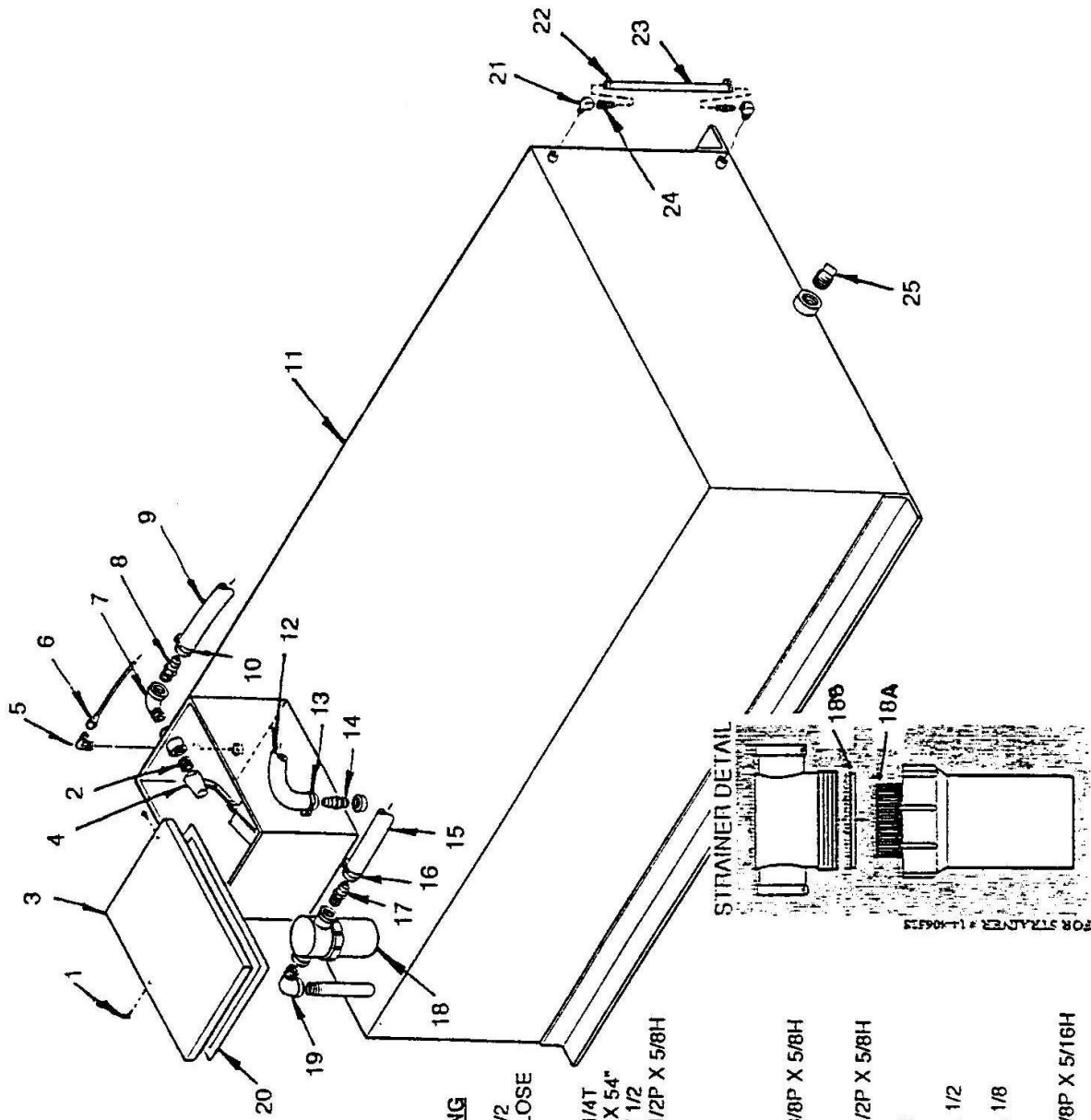

**WATER TANK PARTS LISTING**

- 1 00-000067 SCREW, #10 X 1/2
- 2 11-800068 NIPPLE, 1/2 X CLOSE
- 3 50-501611 LID
- 4 15-808086 FLOAT VALVE
- 5 12-800031 ELBOW, 1/4P X 1/4T
- 6 10-805278 SST HOSE, 3/16 X 54"
- 7 11-800041 STREET ELBOW 1/2
- 8 12-800269 BARB FITTING, 1/2P X 5/8H
- 9 09-805287 HOSE, 5/8 X 42"
- 10 03-000113 HOSE CLAMP
- 11 56-501633 WATER TANK
- 12 09-805321 HOSE, 5/8 X 15"
- 13 03-000113 HOSE CLAMP
- 14 12-800345 BARB FITTING, 3/8P X 5/8H
- 15 09-805268 HOSE, 5/8 X 12"
- 16 03-000113 HOSE CLAMP
- 17 12-800269 BARB FITTING, 1/2P X 5/8H
- 18 14-806530 SCREEN, FILTER
- 18A 43-807041 SEAL FILTER
- 18B 11-800041 STREET ELBOW, 1/2
- 19 43-807070 GASKET, LID
- 20 11-800014 STREET ELBOW, 1/8
- 21 03-000065 HOSE CLAMP
- 22 09-805021 HOSE, 5/16 X 9"
- 23 12-800093 BARB FITTING, 1/8P X 5/16H
- 24 11-800303 PLUG, 1"
- 25

# CARPET WAND PARTS LISTING

WAND ASSEMBLY: #60-950419

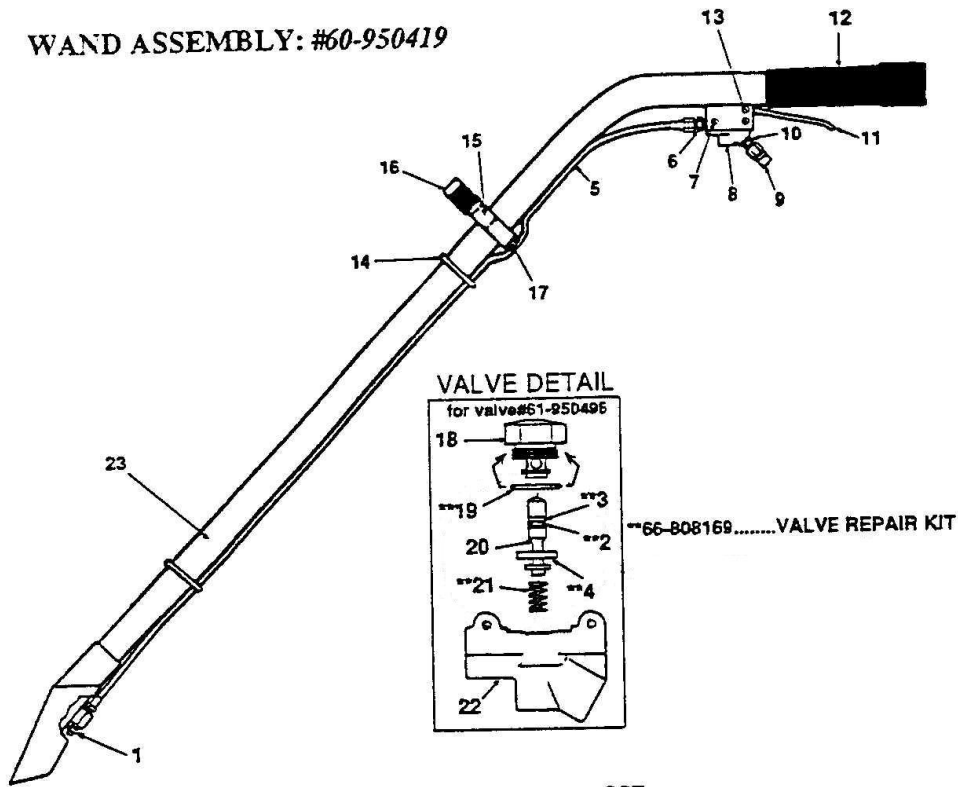

- 1 17-803012.....SPRAY TIP, 11003SST
- 2 43-810062.....O-RING, VALVE
- 3 43-810064.....BACK-UP RING, VALVE
- 4 16-808187.....SEAT, VALVE
- 5 10-805063.....3/16 SST HOSE X 48"
- 6 12-800060.....CONNECTOR, 1/4P X 1/4T
- 7 00-000233.....SCREW, 8-32 X 3/8
- 8 61-950496.....VALVE
- 9 13-806000.....DISCONNECT, 1/4M
- 10 11-800029.....HEX NIPPLE, 1/4
- 11 52-501619.....LEVER
- 12 09-805359.....SLEEVE
- 13 00-000068.....SCREW, 10-32 X 1-1/4"
- 13A 01-000019.....LOCKNUT, 10-32
- 14 04-000053.....NYLON TIE
- 15 52-501577.....HOLD-DOWN, HANDLE
- 16 52-501576.....BODY, HANDLE
- 17 00-000282.....SCREW, HANDLE
- 18 16-808188.....CAP, VALVE
- 19 43-810063.....O-RING, VALVE
- 20 16-808169.....STEM, VALVE
- 21 16-808190.....SPRING, VALVE
- 22 52-501590.....BODY, VALVE
- 23 56-501713.....WAND BODY

## CARPET WAND PARTS LISTING

3-JET WAND ASSEMBLY: #60-950420

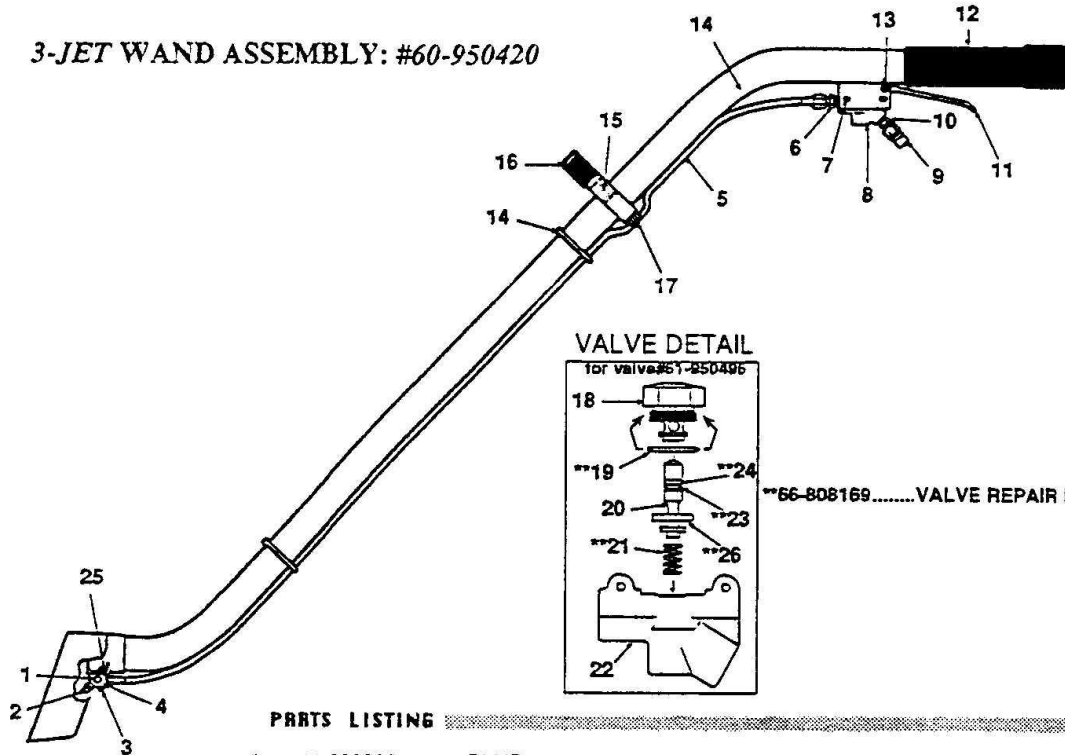

### PARTS LISTING

1	11-800206.....PLUG, 1/8
2	17-803002.....SPRAY TIP,9502 SST
3	00-000042.....SCREW,10-32 X 1"
3A	01-000019.....LOCKNUT, 10-32
4	52-500160.....MANIFOLD
5	10-805063.....3/16 SST HOSE X 48"
6	12-800060.....CONNECTOR, 1/4P X 1/4T
7	00-000233.....SCREW,6-32 X 3/8
8	61-950496.....VALVE
9	13-806000.....DISCONNECT, 1/4M
10	11-800029.....HEX NIPPLE, 1/4
11	52-501619.....LEVER
12	09-805359.....SLEEVE
13	00-000068.....SCREW, 10-32 X 1-1/4"
13A	01-000019.....LOCKNUT, 10-32
14	56-501712.....WAND
15	52-501569.....HOLD-DOWN, HANDLE
16	52-501568.....HANDLE
17	00-000282.....SCREW,HANDLE
18	16-808188.....STEM HOLDER, VALVE
19	43-810063.....O-RING, VALVE
20	16-808169.....STEM, VALVE
21	16-808190.....SPRING, VALVE
22	52-501590.....BODY, VALVE
23	43-810062.....O-RING, VALVE
24	43-810064.....BACK-UP RING, VALVE
25	52-500160.....MANIFOLD
26	16-808187.....SEAT, VALVE

\*\*66-808169.....VALVE REPAIR KIT

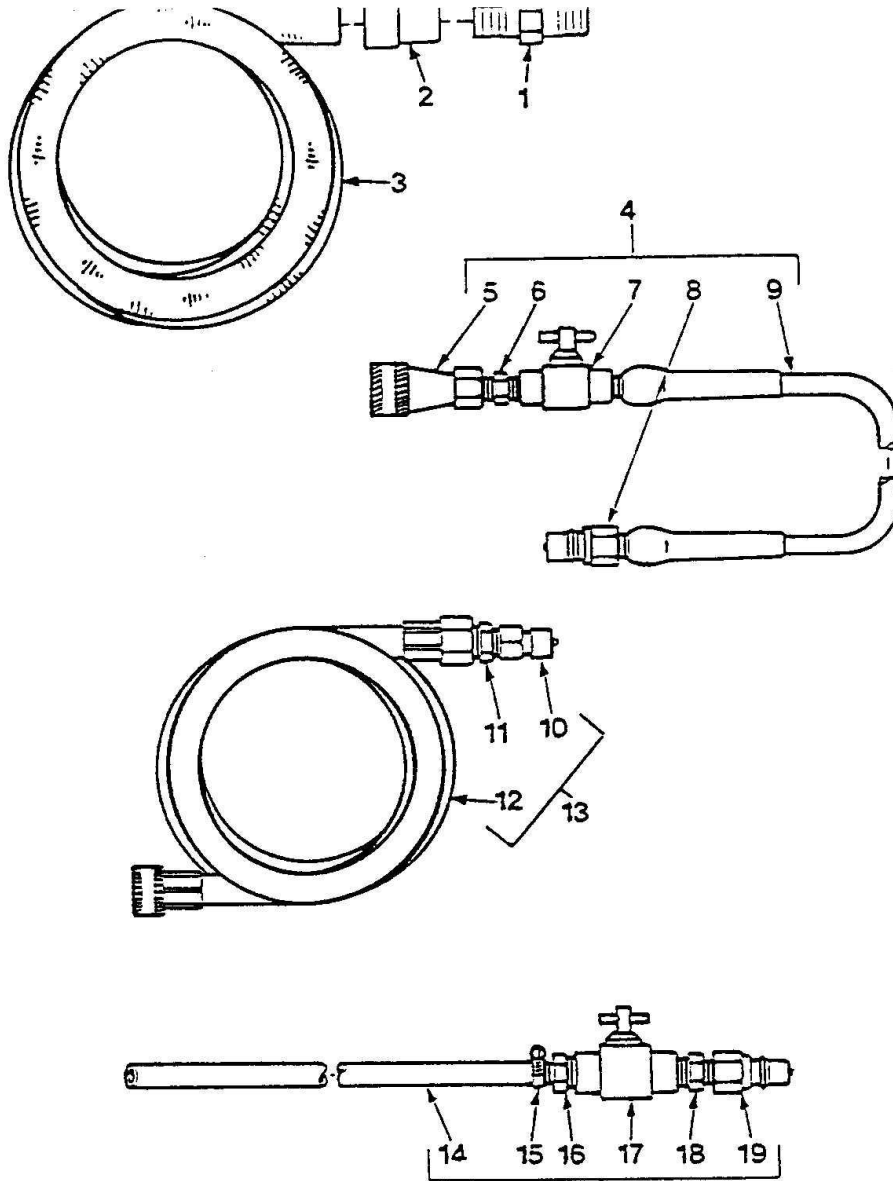

HOSE ACCESSORIES 20

50

- |    |   |    |   |
|----|---|----|---|
| 1  | 12-800078 CONNECTOR                                   | 13 | 10-805295 HOSE ASSY, 1/2 X 50'                        |
| 2  | 08-805147 CUFF  | 14 | 09-805270 RAW HOSE, 3/8 X 36                          |
| 3  | 10-805060 VAC HOSE, 50' W/CUFFS                       | 15 | 03-000065 HOSE CLAMP                                  |
| 4  | 10-805108 HOSE ASSY, 50' W/VALVE                      | 16 | 12-800264 BARB FITTING, 3/8P X 3/8H                   |
| 5  | 13-806001 DISCONNECT, 1/4F                            | 17 | 15-808041 BALL VALVE, 3/8P                            |
| 6  | 11-800029 HEX NIPPLE, 1/4                             | 18 | 11-800151 HEX NIPPLE, 3/8 X 1/4                       |
| 7  | 15-808012 BALL VALVE                                  | 19 | 13-806000 DISCONNECT, 1/4M                            |
| 7A | 43-810014 O-RING (1)                                  | 20 | 10-805268 HOSE, CONV. OUTLET                          |
| 7B | 43-810019 O-RING (2)                                  |    |   |
| 8  | 13-806000 DISCONNECT, 1/4M                            |    | NOT SHOWN   |
| 9  | 10-805077 HOSE ASSY, 1/4 X 50'<br>WITHOUT DISCONNECTS | 21 | 10-805122 HOSE ASSY, 1/4 X 50'<br>WITH DISCONNECTS    |
| 10 | 13-806009 DISCONNECT, 3/8M                            | 22 | 65-950078 HOSE REEL                                   |
| 11 | 11-800354 HEX NIPPLE, 1/2 X 3/8                       | 23 | 10-805309 HOSE ASSY, 1/4 X 25'<br>WITHOUT DISCONNECTS |
| 12 | 10-805157 HOSE, 1/2 X 50'                             |    |   |

# SOLUTION OUTLET SYSTEM

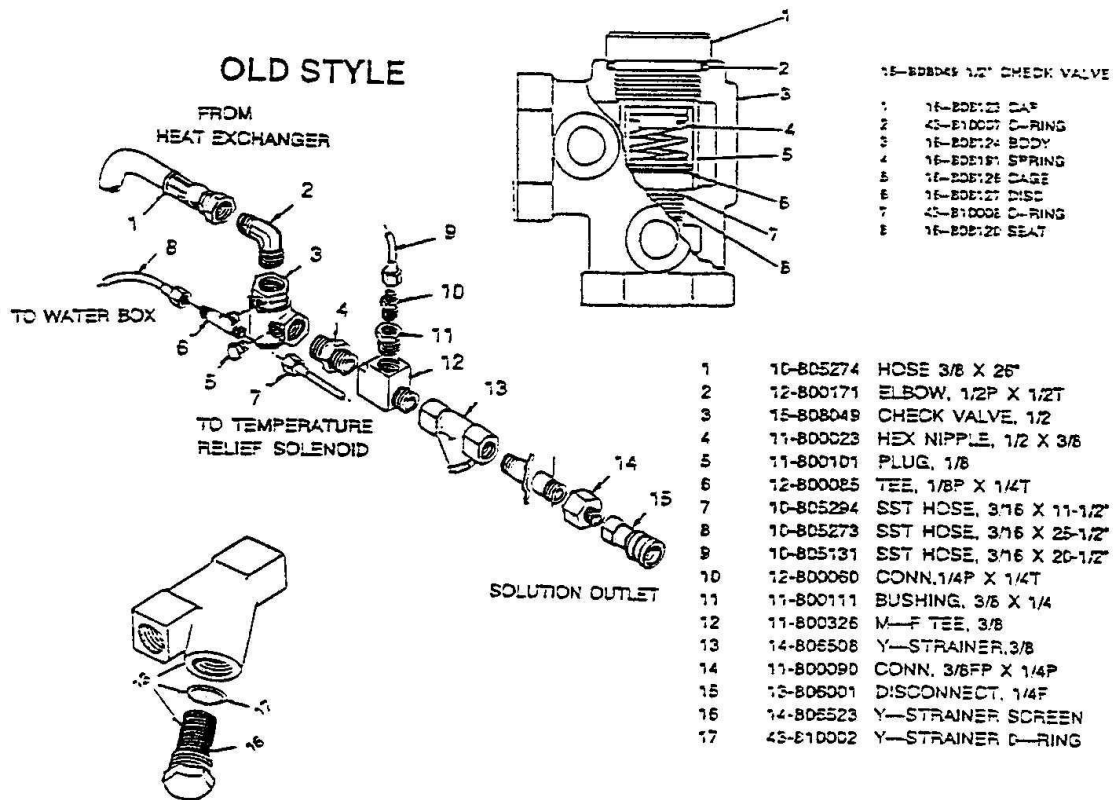
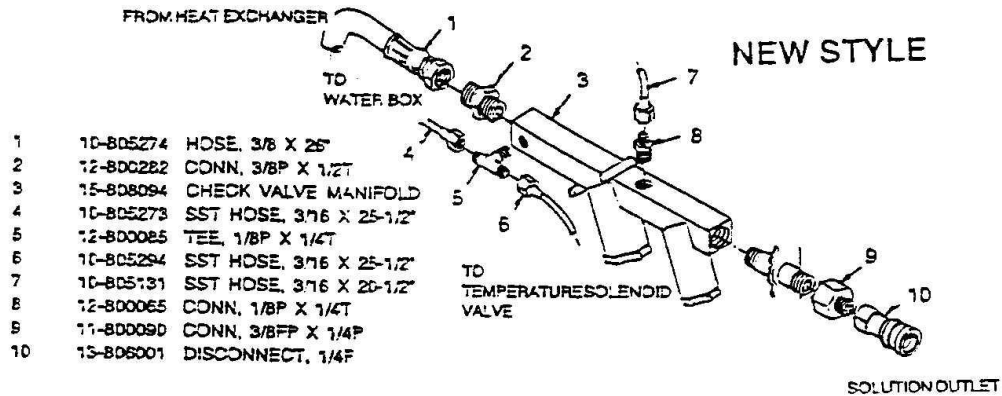

### STAIR TOOL PARTS LISTING

- 1 56-501715.....STAIR TOOL BODY
- 2 17-803003.....SPRAY TIP, 11002 SST
- 3 10-805330.....3/16" SST HOSE x 14"
- 4 04-000953.....NYLON TIE
- 5 00-000282.....SCREW, 1/4 x 1-1/4"
- 6 52-501569.....HOLD-DOWN HANDLE
- 7 12-800060.....CONNECTOR, 1/4P x 1/4I
- 8 61-950496.....VALVE
- 9 11-800029.....HEX NIPPLE, 1/4"
- 10 13-806000.....DISCONNECT, 1/4AM
- 11 52-501619.....TRIGGER VALVE
- 12 49-802525.....GRIP SLEEVE
- 13 00-000233.....SCREW, 8-32 x 3/8"
- 14 00-000048.....LOCKNUT, 10-32 x 1-1/4"
- 14A 01-000019.....BODY, HANDLE
- 15 52-501668.....CAP VALVE
- 16 16-808188.....O-RING, VALVE
- 17 43-810064.....BACK-UP RING, VALVE
- 18 43-810062.....O-RING, VALVE
- 19 16-808189.....STEM, VALVE
- 20 16-808190.....SPRING, VALVE
- 21 16-808187.....SEAT, VALVE
- 22 52-501590.....BODY, VALVE
- 23 48-941163.....DECAL, STAIR TOOL
- 24

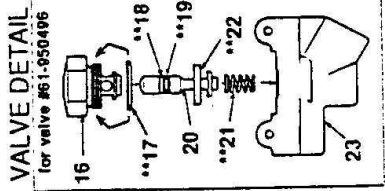

\*\*66-808169.....VALVE REPAIR KIT

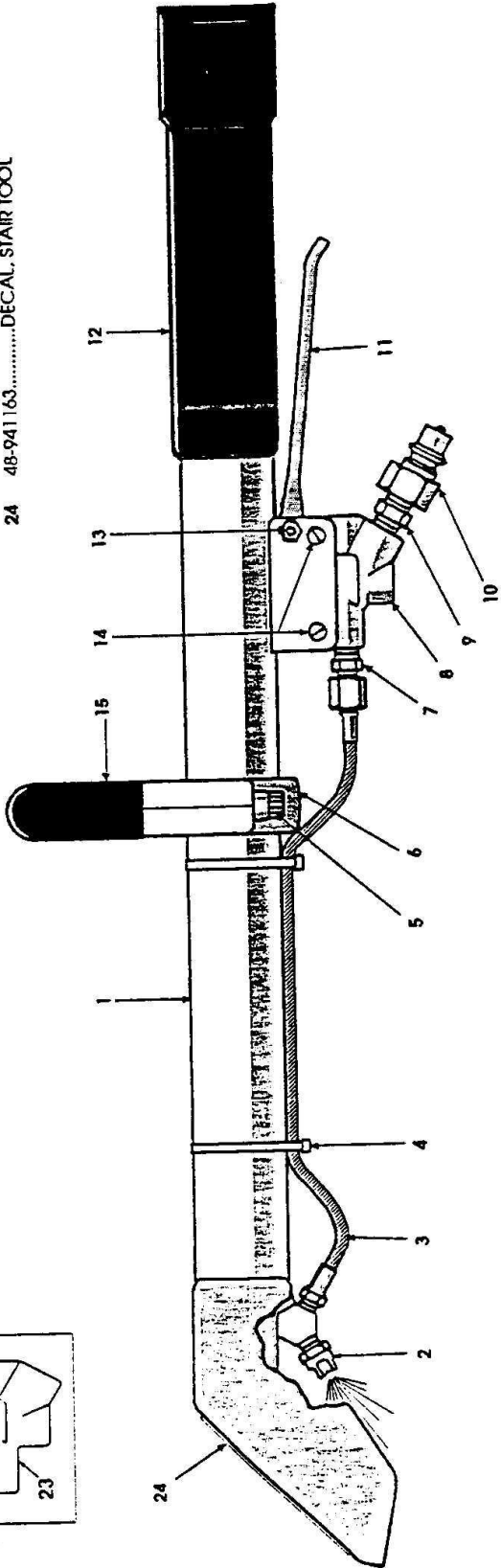

## HEAT EXCHANGER PIPING

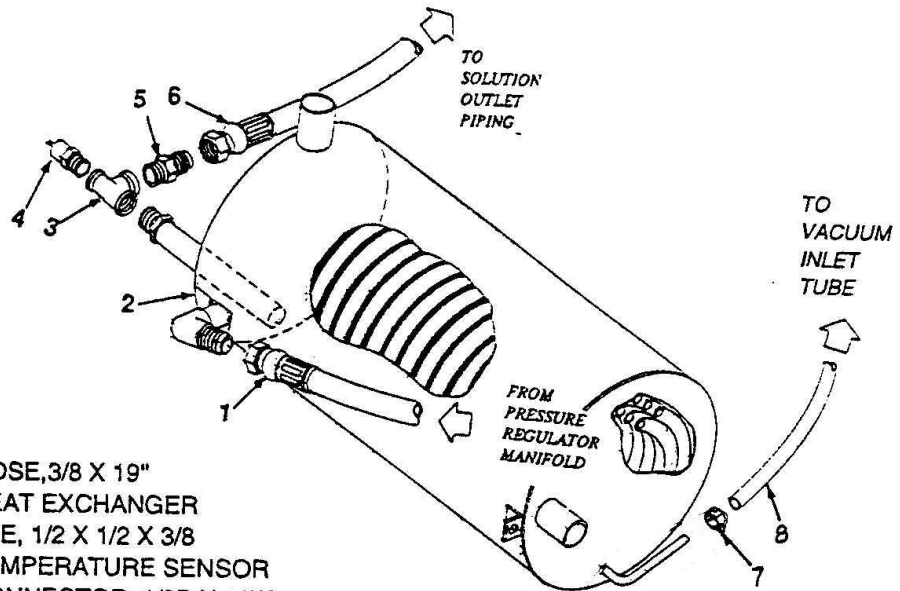

- 1 10-805275 ..... HOSE, 3/8 X 19"
- 2 57-520069 ..... HEAT EXCHANGER
- 3 11-800115 ..... TEE, 1/2 X 1/2 X 3/8
- 4 35-900050 ..... TEMPERATURE SENSOR
- 5 12-800141 ..... CONNECTOR, 1/2P X 1/2T
- 6 10-805346 ..... HOSE, 3/8 X 24"
- 7 03-000065 ..... HOSE CLAMP
- 8 09-805180 ..... HOSE, 5/16 X 10"

## TEMPERATURE SOLENOID PARTS DETAIL

- 1 10-805130.....HOSE, 3/16SST x 13-1/2"
- 2 12-800031.....ELBOW, 1/4P x 1/4T
- 3 15-808000.....TEMPERATURE SOLENOID
- 4 10-805311.....HOSE, 3/16SST x 10-1/2"
- 5 50-501610.....MOUNT, SOLENOID
- 6 02-000032.....LOCKWASHER, #10
- 7 00-000031.....SCREW, 10-24 x 1/2"
- 8 02-000066.....FLATWASHER, 1/4
- 9 02-000038.....LOCKWASHER, 1/4
- 10 00-000070.....SCREW, 1/4-20 x 1/2"

